

CATÁLOGO DE  
RECAMBIO

CATALOGUE PIECES  
DETACHES

PARTS CATALOG

**MERLIN**

**063 Fius 1**

INFORMACIÓN GENERAL  
INFORMATION GENERAL  
GENERAL INFORMATION



**INFORMACIÓN GENERAL**

- Este catálogo ha sido preparado para facilitar el pedido de recambios. En sus pedidos indicar siempre:

- 1) Cantidad, referencia y descripción de las piezas.
- 2) Color de la pieza; si hay diversas opciones.
- 3) Número de la identificación del bastidor.

Las indicaciones "derecha" o "izquierda", se refieren a los lados de la moto, con el piloto sentado sobre el asiento.

**NOTAS  
NOTES  
NOTES**

H.N. D.N.	Hasta chasis N.º Desde chasis N.º	Jusqu'an chasis N.º Du chasis numero	Until V.I.N From V.I.N
D Ch F USA	Alemania Suiza Francia Estados Unidos	Allemagne Suisse France Etats Unis d'Amérique	Germany Switzerland France United States
I GB E	Italia Gran Bretaña España	Italie Grand Bretagne Espagne	Italy Great Britain Spain

**INFORMATION GENERAL**

- Ce catalogue a été préparé pour faciliter le client dans sa commande des pièces de Rechange.

Pour toute commande indiquer toujours:

- 1) Quantité, référence et description.
- 2) Couleur des pièces peintes.
- 3) Numéro d'identification (chassis) de la motocyclette.

Les indications "droite" et "gauche" se rapportent aux deux cotes de la moto par rapport au conducteur assis sur la selle.

**GENERAL INFORMATION**

- This catalog has been prepared for your convenience when ordering parts. When ordering parts, follow these instructions:

- 1) Quantity, part number and description.
- 2) Indicate color for painted parts.
- 3) Indicate motorcycle V.I.N.

"Right side" "left side" indicated in this catalog are referred to rider seating on motorcycle.



ESPECIFICACIONES TÉCNICAS  
ESPECIFICATIONS TECHNIQUES  
TECHNICAL SPECS



**NEUMATICOS**

Delante .....
Presión recomendada .....
Competición .....
Normal .....
Trasero .....
Presión recomendada .....
Competición .....
Normal .....

**SUSPENSION**

Delante recorrido .....
Trasera recorrido .....

**LUBRICANTES Y FLUIDOS**

Motor .....
Suspensión delantera .....
Gasolina .....
Aceite mezcla .....
Líquido freno .....
Filtro aire .....

**TOLERANCIAS**

Cilindro-pistón .....
Normal .....
Limite .....
Apertura aros .....
Normal .....
Limite .....

**PARES APRIETE**

Tuerca culata .....
Tornillo cilindro .....
Engran cigüeñal .....
Encendido .....
Bujía .....
Embrague .....

**PARES APRIETE ESTANDAR**

MM	KG - M
5	0,35 - 0,50
6	0,6 - 0,8
8	1,4 - 1,9
10	2,6 - 3,5
12	4,5 - 6,2
14	5,5 - 7,5

**PNEUS**

Avant .....
Presion recomende .....
Competition .....
Normale .....
Arriere .....
Presion recomandie .....
Competition .....
Normale .....

**SUSPENSION**

Debatement avant .....
Debatement arriere .....

**LUBRICANTS ET FLUIDES**

Moteur .....
Suspension avant .....
Essence .....
Huile Melange .....
Liquide freines .....
Filtre aire .....

**TOLERANCES**

cilindre-piston .....
Normal .....
Limit .....
Segment piston .....
Normal .....
Limit .....

**COUPLE SERRAGE**

Encrou culasse .....
Vis cilindre .....
Engr. vilebrequin .....
Allumage .....
Bougie .....
Embrayage .....

**COUPLE SERRAPE STANDARD**

N - M
3,4 - 4,9
5,9 - 7,8
14,0 - 19,0
25,0 - 34,0
44,0 - 61,0
53,7 - 73,0

**TIRES**

Front .....	2.75 X 21" Tubeless
Suggested tire pressure .....	
Race .....	0, 45 Kg/cm <sup>2</sup> • 6'5 P.S.I
Normal Use .....	1,2 Kg/cm <sup>2</sup> • 16,8 P.S.I
Rear .....	4.00 X 18" tubeless
Suggested tire pressure .....	
Race .....	0.35 Kg/cm <sup>2</sup> • 4,6 P.S.I.
Normal Use .....	1.2 Fg/Km <sup>2</sup> • 16,8 P.S.I

**SUSPENSION**

Front travel .....	175 mm • 6.89 in
Rear travel .....	200 mm • 7.87 in

**LUBRICANTS AND FLUIDS**

Engine .....	1.300 c.c. • 1'4 US qt. SAE 10W40/ 20W50
Front fork .....	240 c.c. • 0'25 US qt. SAE 20
Petrol .....	94 - 98 N.O • Octane • rate.
Gas Mixture .....	2% • 50:1
Brake fluid .....	DOT 4
Air filter foam .....	Especial filtro aire • Special air filter oil • Special air filter

**CLEARANCES**

cylinder-piston .....	
Standart .....	0'02 - 0'03 mm • 0'00078 - 0'0011 in
Service limit .....	0'08 mm • 0'0031 in
Piston Ring Gap .....	
Standard .....	0'25 - 0'35 mm • 0'0098 - 0'0137 in
Service limit .....	1'0 mm • 0'039 in

**TIGHTENING TORQUE**

	Kg.m	N.m	Ft.Lb
Cyl. head nut .....	2.0-2.2	19.6-21.6	14.4-15.8
Cylinder bolts .....	2.8-3.0	27.4-29.4	20.16-21.6
Crankshaft gear nut .....	6-6.2	58.8-60.8	43.4-44.8
Ignition flywheel .....	5.0-5.2	49-51	36.1-37.5
Spark plug .....	3.5-3.9	34.3-38.2	25.3-28.2
Clutch hub .....	3.0-3.2	29.4-31.4	21.6-23.1

**STANDARD TIGHTENING TORQUE**

LB - FT
2,5 - 35
4,5 - 5,5
10,0 - 13,5
19,0 - 25,0
33,0 - 45,0
40,3 - 73,3



INSTALACIÓN ELÉCTRICA  
EQUIPEMENT ELECTRIQUE  
ELECTRIC SYSTEM



INSTALACIÓN ELÉCTRICA

1	Generador 12v-95w	6	Avisador acústico
2	Bobina A.T.	7	Interruptor stop
3	Centralita	8	Faro piloto 12v/21-5w
4	Conmutador luces	9	Regulador
5	Faro anterior 12v 35/35w		

A	Rojo	G	Verde
B	Rojo - Blanco	H	Marron
C	Negro	I	Rosa
D	Negro - Blanco	J	Azul
E	Amarillo	K	Blanco - Azul
P	Amarillo - Verde		

ELECTRIC SYSTEM

1	Generator 12v-95w	6	Horn
2	H.T. Coil	7	Rear brake stop light switch
3	Ignition modul	8	Tail light 12v/21-5w
4	Light switch	9	Regulator
5	Head light 12v 35/35w		

A	Red	G	Green
B	Black	H	Brown
C	Black	I	Pink
D	Black - White	J	Blu
E	Yellow	K	White - Blu
P	Yellow - Green		

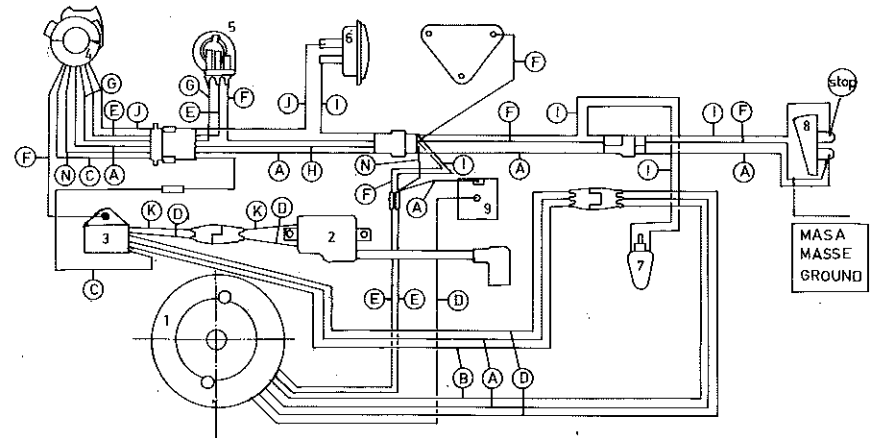

EQUIPEMENT ELECTRIQUE

1	Volant - Alternateur 12v - 95w	6	Claxon
2	Bobine H.T.	7	Interrupteur feu stop
3	Modul allumage	8	Feu arriere 12 v/21-5w
4	Interrupteur guidon	9	Regulateur
5	Phare 12 v 35/35w		

A	Rouge	G	Vert
B	Rouge - Blanc	H	Marron
C	Noire	I	Rose
D	Noire - Blanc	J	Bleu
E	Jaune	K	Blanc - Bleu
F	Jaune - Vert		

DEPOSITO, GUARDABARROS, ASIENTO  
RESERVOIRE, GARDEBOUES, SELLE  
GAS TANK, MUDGUARDI, SEAT

LAMINA-1

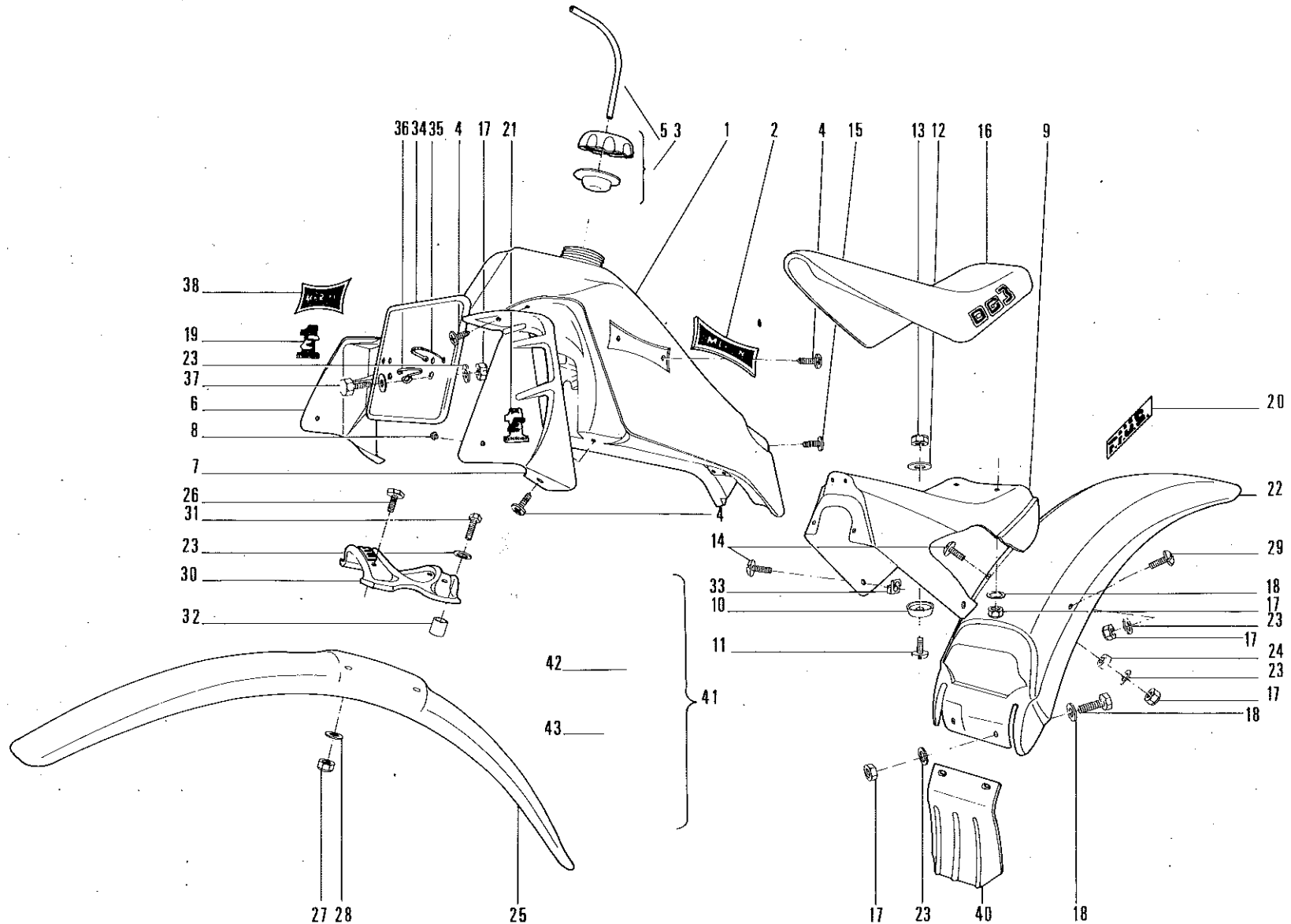

DEPOSITO, GUARDABARROS, ASIENTO  
RESERVOIRE, GARDEBOUES, SELLE  
GAS TANK, MUDGUARDI, SEAT

LAMINA-1

MERLIN

N.º NRO. NBR	REFERENCIA REFERENCE REFERENCE	Denominación	Designation	Description	Cantidad QTE QTY	VALIDEZ VALIDITE VALIDITY						
1	013.00.007-0	Deposito gasolina	R�sservoir essence	Gas tank	1		20	013.03.029-0	Adhesivo FIUS	Decalcomanie FIUS	FIUS stickers	2
2	013.00.018-0	Anagrama	Decalcomanie	Trim	2		21	017.03.029-0	Adhesivo E-1	Decalcomanie E-1	E-1 sticker	2
3	013.00.008-0	Tap�n dep�sito	Bouchon	Gas cap	1		22	013.00.006-0	Guardabarros	Gardeboue	Mudguard	1
4	026.98.001-1	Tornillo	Vis	Bolt	8		23	061.98.004-1	Arandela	Rondelle	Washer	10
5	013.00.051-0	Tubo desvaporizador	Tuyau	Breather hose	1		24	013.10.038-0	Casquillo	Entretoise	Bushing	1
6	013.00.054-0	Spoiler derecho	Protection drte.	right guard	1		25	013.00.005-0	Guardabarro	Gardeboue	Mudguard	1
7	013.00.053-0	Spoiler izquierdo	Protection gche.	Left guard	1		26	002.98.003-1	Tornillo	Vis	Bolt	4
8	013.00.052-0	Bot�n antical�rico	Caoutchouc	Rubber grommet	2		27	045.98.006-1	Tuerca	Ecrou	Nut	4
9	013.00.030-0	Soporte sillin	Suport selle	Seat support	1		28	061.98.057-1	Arandela	Rondelle	Washer	4
10	013.00.065-0	Goma apoyo	Caoutchouc	Rubber grommet	2		29	032.98.003-3	Tornillo	Vis	Bolt	1
11	032.98.002-3	Tornillo	Vis	Bolt	2		30	013.00.021-0	Puente guardabarro	Support gardeboue	Fender support	1
12	061.98.056-1	Arandela plana	Rondelle	Washer	2		31	007.98.016-1	Tornillo	Vis	Bolt	4
13	045.98.005-1	Tuerca	Ecrou	Nut	2		32	013.00.066-1	Casquillo	Entretcise	Bushing	4
14	032.98.001-3	Tornillo	Vis	Bolt	3		33	054.98.201-0	Tuerca	Ecrou	Nut	2
15	026.98.002-0	Tornillo	Vis	Bolt	4		34	003.08.006-0	Placa N.�	Plaque N.�	Number plate	1
16	013.00.011-0	Sillin	Selle	Seat	1		35	134.98.401-9	Abrazadera	Collier	Clamp	2
17	045.98.004-1	Tuerca	Ecrou	Nut	8		36	003.09.005-0	Gu�a	Guide	Guide	1
18	061.98.952-1	Arandela	Rondelle	Washer	5		37	002.98.002-1	Tornillo	Vis	Bolt	1
19	017.03.029-1	Adhesivo E-1	Decalcomanie E-1	E-1 sticker	1		38		Adhesivo	Decalcomanie	Sticker	1
							39	007.98.007-1	Tornillo	Vis	Bolt	2
							40	013.03.028-0	Protecci�n	Protecteur	Protector	1
							41	013.00.039-0	Cto. grifo gasolina	Robinet compl.	Gas tap assy	1
							42	145.98.004-0	Junta t�rica	Joint	Gasket	1
							43	026.98.002-0	Tornillo	Vis	Bolt	2

FILTRO AIRE, TUBO ESCAPE  
FILTRE AIRE, TUYAU ECHAPEMENT  
AIR FILTER, EXHAUST SYSTEM

LAMINA-2

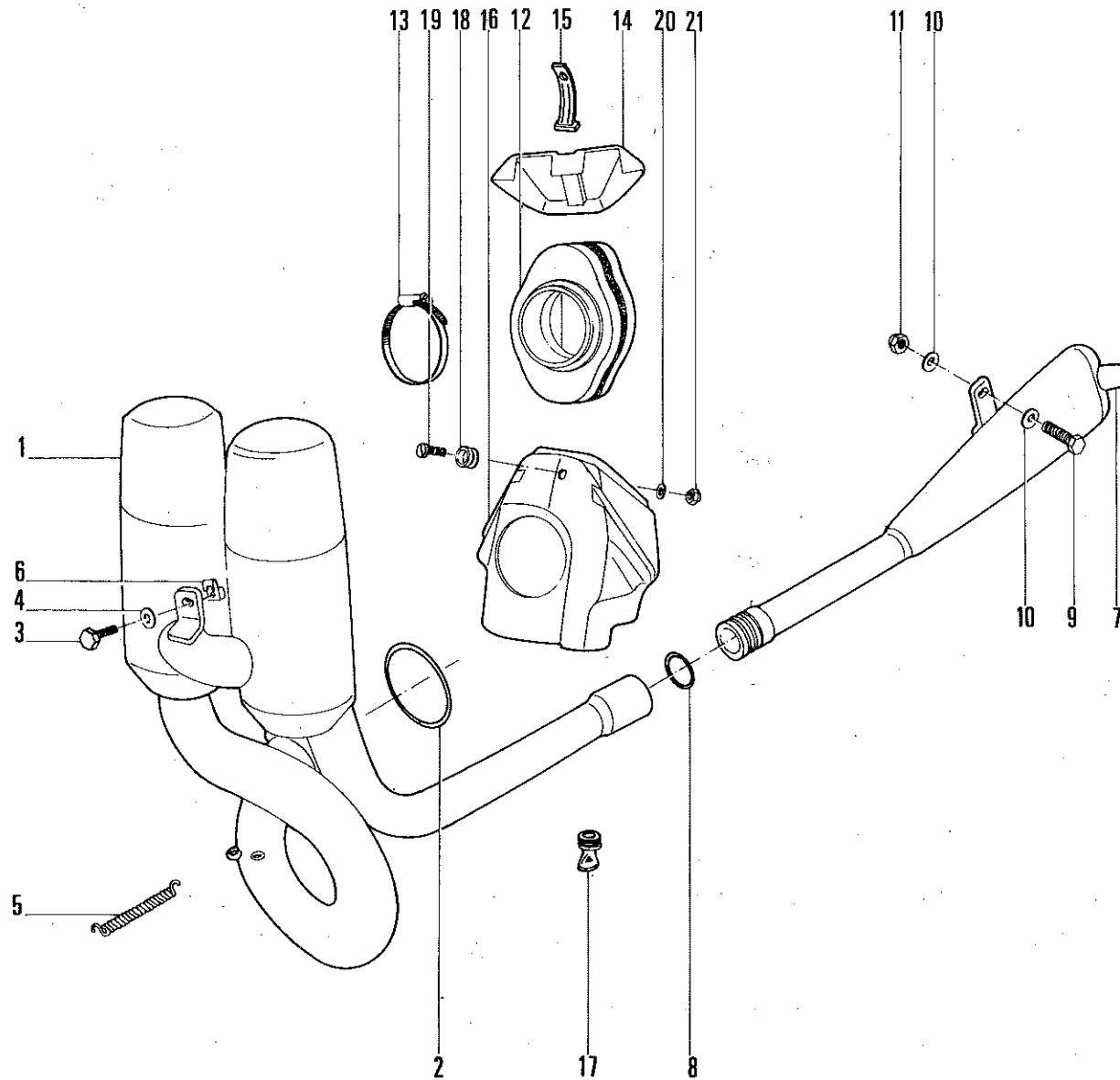

FILTRO AIRE, TUBO ESCAPE  
 FILTRE AIRE, TUYAU ECHAPEMENT  
 AIR FILTER, EXHAUST SYSTEM

LAMINA-2



N.º NRO NBR	REFERENCIA REFERENCE REFERENCE	Denominación	Designation	Description	Cantidad QTE QTY	VALIDEZ VALIDITE VALIDITY
1	013.07.001-0	Tubo escape	Tuyau echape- ment	Exhaust pipe	1	
2	145.98.005-0	Junta	Jointe	Gasket.	1	
3	002.98.002-1	Tornillo	Vis	Bolt	1	
4	061.98.052-1	Arandela	Rondelle	Washer	1	
5	003.07.004-0	Muelle	Resort	Spring	2	
6	054.98.201-0	Tuerca	Ecrou	Nut	1	
7	013.07.003-0 013.07.003-1	Silenciador Silenciador Francia	Silencieux Silencieux France	Silencer Silencer France	1 1	
8	145.98.006-0	Junta	Jointe	Gasket	3	
9	002.98.006-1	Tornillo	Vis	Bolt	1	
10	061.98.003-1	Arandela	Rondelle	Washer	2	
11	045.98.003-1	Tuerca	Ecrou	Nut	1	
12	013.15.006-0	Filtro	Filtre	Air filter	1	
13	134.98.003-1	Abrazadera	Collier	Hose clamp	1	
14	013.15.007-0	Tapa filtro	Couvercle	Cover	1	
15	013.15.011-0	Goma	Collier elastique	Rubber strap	1	
16	013.15.005-0	Caja filtro	Coite du filtre	Air filter box	1	
17	013.15.009-0	Válvula goma	Cautchou sor- tie eau	Rubber drain valve	1	
18	013.15.012-0	Casquillo	Entretoise	Bushing	1	
19	016.98.002-0	Tornillo	Vis	Bolt	1	
20	061.98.056-1	Arandela	Rondelle	Washer	1	
21	042.98.001-1	Tuerca	Ecrou	Nut	1	

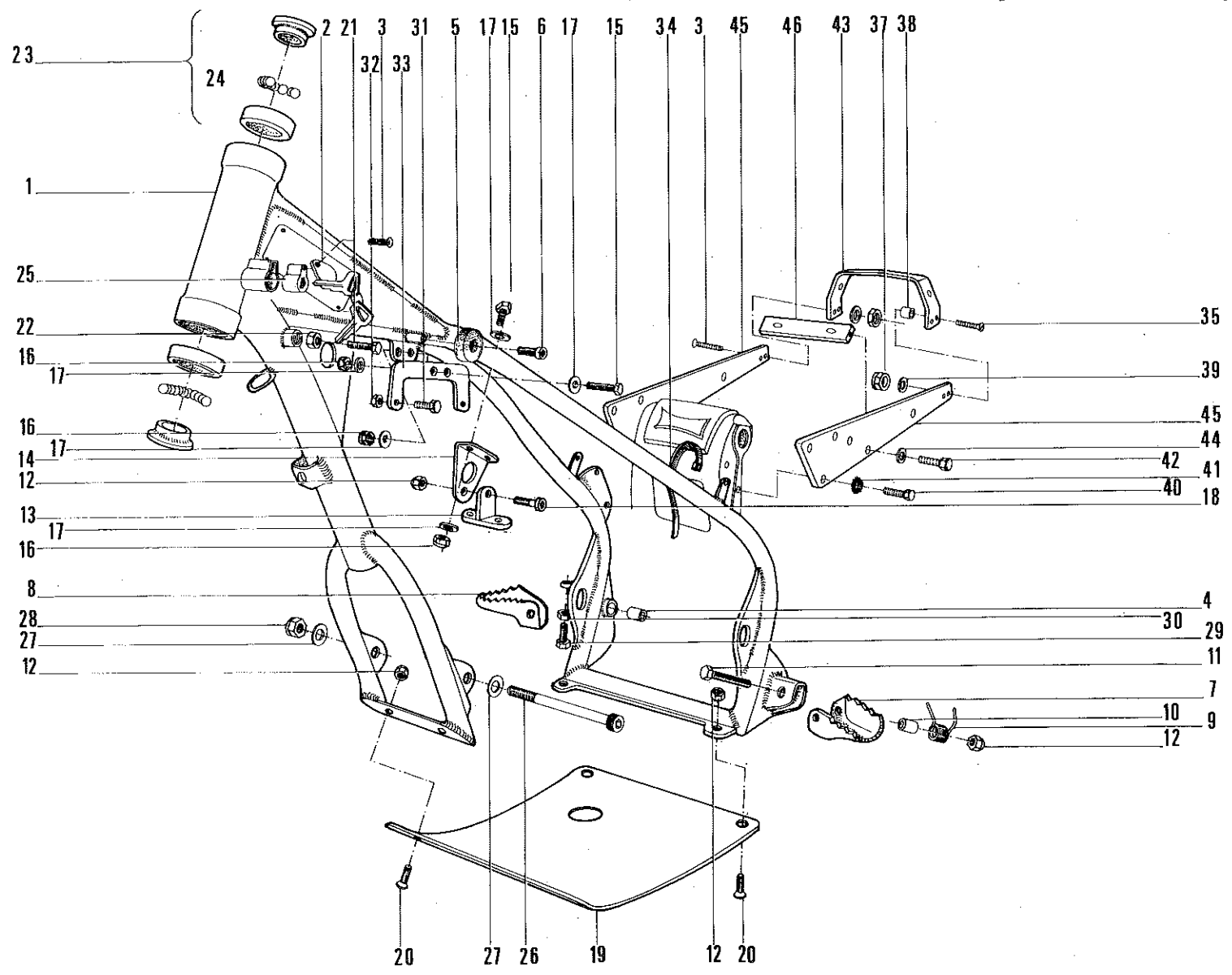



N.º NRO. NBR.	REFERENCIA REFERENCE REFERENCE	Denominación	Designation	Description	Cantidad QTE QTY	VALIDEZ VALIDITE VALIDITY	N.º NRO. NBR.	REFERENCIA REFERENCE REFERENCE	Denominación	Designation	Description	Cantidad QTE QTY	VALIDEZ VALIDITE VALIDITY
1	017.00.016-0	Bastidor	Chasis	Frame	1		31	002.98.004-1	Tornillo	Vis	Bolt	2	
2	003.00.063-0	Tapa cerradura	Couvercle	Lock cover	1		32	045.98.005-1	Tuerca	Ecrou	Nut	2	
3	003.00.064-0	Pasador	Vis	Lock cover pin	1		33	003.17.005-0	Plancha	Support	Support	1	
4	150.98.201-0	Cojinete fricción	Douille	Friction bearing	1		34	134.98.401-9	Abrazadera nylon	Collier nylon	Nylon clamp	6	
5	013.00.010-0	Soporte goma	Rondelle caout- chou	Rubbert support	2		35	022.98.003-1	Tornillo	Vis	Bolt	2	
6	012.98.001-1	Tornillo	Vis	Bolt	2		36	022.98.001-1	Tornillo	Vis	Bolt	2	
7	003.00.002-1	Estribo izdo.	Repose pie gche	Left footpeg	1		37	045.98.005-1	Tuerca	Ecrou	Nut	4	
8	003.00.001-1	Estribo dcho.	Repose pie dte.	Right footpeg	1		38	003.06.004-0	Casquillo	Entretoise	Bushing	2	
9	003.00.003-1	Muelle estribo	Ressort	Spring	2		39	061.98.002-1	Arandela	Rondelle	Washer	6	
10	003.00.004-1	Casquillo	Entretoise	Bushing	2		40	002.98.006-1	Tornillo	Vis	Bolt	4	
11	007.98.002-1	Tornillo	Vis	Bolt	2		41	064.98.006-0	Arandela	Rondelle	Washer	4	
12	045.98.003-1	Tuerca	Ecrou	Nut	7		42	002.98.004-1	Tornillo	Vis	Bolt	2	
13	003.00.020-1	Soporte culata	Support	Support	1		43	013.00.056-0	Puente guardabarro	Pont gardebou	Fender support	1	
14	013.00.019-0	Soporte	Support	Head Steady	1		44	061.98.002-1	Arandela	Rondelle	Washer	2	
15	002.98.002-1	Tornillo	Vis	Bolt	4		45	013.00.055-0	Perfil lateral	Lateral	Side support	2	
16	045.98.004-1	Tuerca	Ecrou	Nut	4		46	013.00.057-0	Rectángulo	Rectángulo	Union	1	
17	061.98.004-1	Arandela	Rondelle	Washer	6								
18	012.98.006-1	Tornillo	Vis	Bolt	1								
19	013.00.023-0	Placa protección	Sabot	Skid plate	1								
20	023.98.002-1	Tornillo	Vis	Bolt	4								
21	002.98.007-1	Tornillo	Vis	Bolt	2								
22	037.98.005-0	Tuerca	Ecrou	Nut	2								
23	003.01.003-0	Cto. Cojinete	Roulement	Bearing	2								
24	003.01.002-0	Esfemas	Esféres	Sphere	44								
25	003.00.027-0	Cerradura	Serrure	Lock assy	1								
26	012.98.010-1	Tornillo	Vis	Bolt	1								
27	061.98.001-1	Arandela	Rondelle	Washer	2								
28	045.98.001-1	Tuerca	Ecrou	Nut	1								
29	002.98.010-1	Tornillo	Vis	Bolt	1								
30	042.98.002-1	Tuerca	Ecrou	Bolt	1								

SUSPENSIÓN DELANTERA  
SUSPENSION AVANT  
FRONT SUSPENSION

LAMINA-4

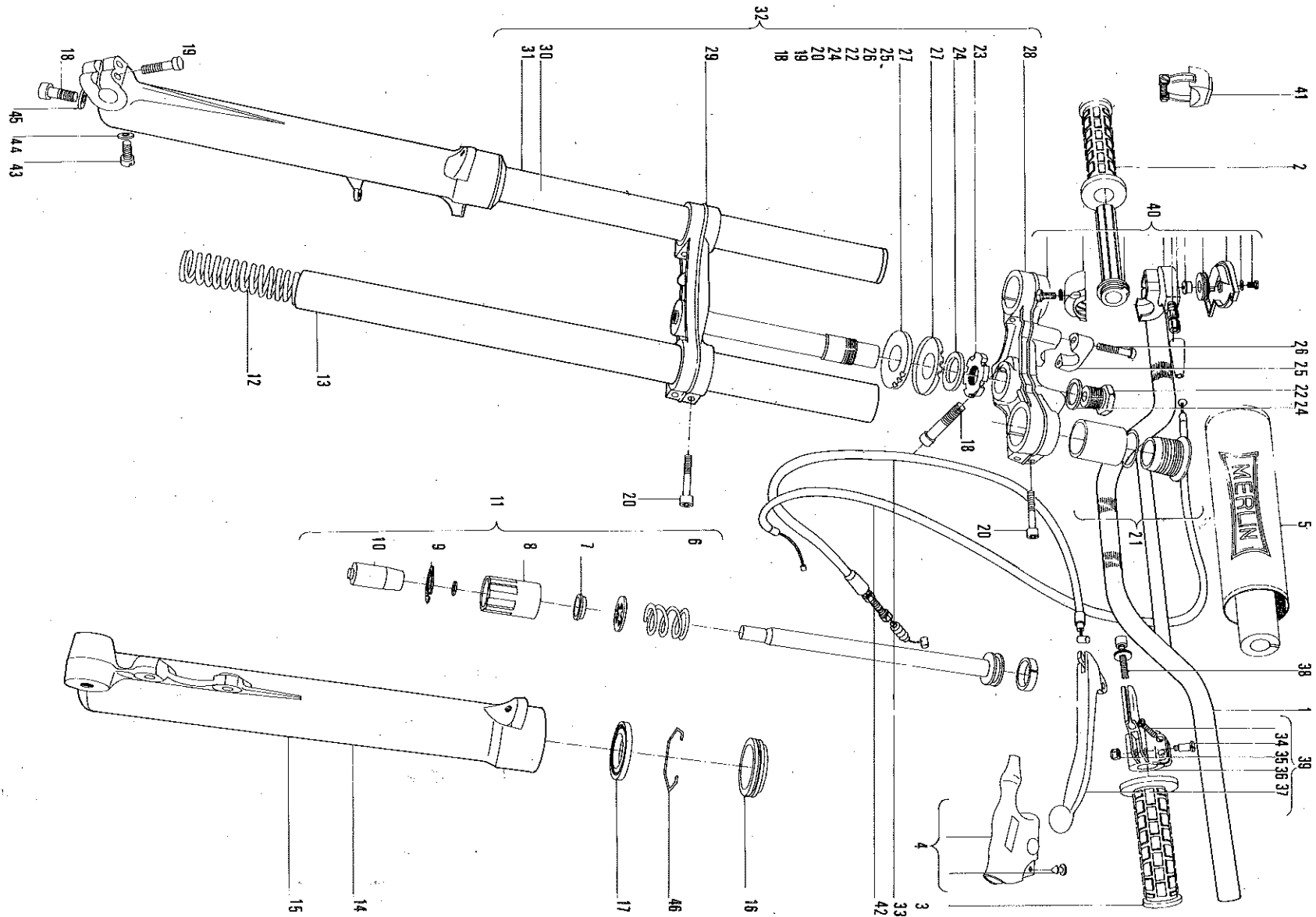

# LAMINA-4

MERLIN

SUSPENSIÓN DELANTERA  
SUSPENSION AVANT  
FRONT SUSPENSION

N.º NBR	REFERENCIA REFERENCE	Denominación	Designation	Description	Cantidad QTE	VALIDEZ VALIDITE VALIDITY
1	003.01.004-0	Manillar	Guidon	Handlebar	1	
2	003.01.006-0	Empuñadura dcha	Poignée D.	Right S. grip	1	
3	003.01.005-0	Empuñadura Izda.	Poignée G.	Left S. grip	1	
4	003.01.007-0	Protéc. maneta	Protéc. levier	Lever protector	1	
5	013.01.009-0	Protector	Protecteur	Protector	1	
6	013.02.034-1	Segmento	Segment	Piston ring	2	
7	013.02.031-1	Arandela Válvula	Rondelle soupape	Washer valve	2	
8	013.02.032-1	Cilindro	Cilindre	Cylinder	2	
9	093.98.002-0	Seeger	Seeger	Seeger	2	
10	013.02.021-1	Válvula	Soupape	Valve	2	
11	013.02.007-1	Cto Hidráulico	Amortisseur complet	Damper tube assy	2	
12	013.02.002-1	Muelle sus- pensión	Resort	Spring	2	
13	013.02.003-1	Tubo	Barre de force	Stanchion	2	
14	013.02.004-1	Botella dcha.	Bouteille droite	Right side slider	1	
15	013.02.005-1	Botella izda.	Bouteille g.	Left s. slider	1	
16	013.02.008-1	Guarda polvo	Protecteur	Dust cover	2	
17	135.98.101-0	Retén	Bourrage	Oil seal	2	
18	012.98.105-1	Tornillo	Vis	Bolt	2	
19	022.98.011-1	Tornillo	Vis	Bolt	2	
20	012.98.104-1	Tornillo	Vis	Bolt	8	
21	013.02.006-1	Cto. tapón	Bouchon cpl.	Fork cap assy	2	
22	013.02.016-0	Tapón tija	Bouchon	Steering cap.	1	
23	013.02.017-2	Tuerca direc- ción	Ecrou direction	Steering adj. nut	1	
24	013.02.027-1	Arandela	Rondelle	Washer	2	
25	013.02.024-0	Tapeta manillar	Eton	Clamp	2	
26	012.98.103-1	Tornillo	Vis	Bolt	4	
27	003.02.018-1	Cazoleta	Protection	Shield	2	
28	013.02.014-1	Brida sup.	Pont. supérieur	Top triple clamp	1	
29	013.02.013-1	Brida inferior	Pont inférieur	Bottom triple clamp	1	
30	013.02.010-1	1/2 susp. dcha	1/2 susp. D.	Ringt fork leg assy	1	
31	013.02.011-1	1/2 susp. izda.	1/2 susp. gau- che	Left fork leg assy	1	
32	013.02.001-1	Cto. susp. delantera	Susp. ant. complete	Front fork assy	1	
33	003.14.002-0	Cable embra- gue	Cable embra- yage	Clutch cable	1	
34	003.14.007-0	Eje leva embra- gue	Axe levier	Clutch lever pin	1	
35	003.14.016-0	Tuerca With- worth	Ecrou with- worth	Withworth nut	1	
36	003.14.012-0	SopORTE	Support	Bracket	1	
37	017.14.013-0	Leva	Lever	Lever	1	
38	003.14.004-0	Tensor cable	Tendeur cable	Cable tensioner	1	
39	017.14.003-0	Cto. mando embrague	Levier embra yage complete	Clutch lever assy	1	
40	013.15.003-0	Cto. mando rador	Com. gas comp.	Throttle assy	1	
41	002.18.001-0	Botón de paro	Bouton stop	Kill bottom	1	
42	003.15.002-0	Cto. cable gas	Cable gas	Throttle cable	1	

SUSPENSIÓN TRASERA  
SUSPENSION ARRIERE  
REAR SUSPENSION

LAMINA-5

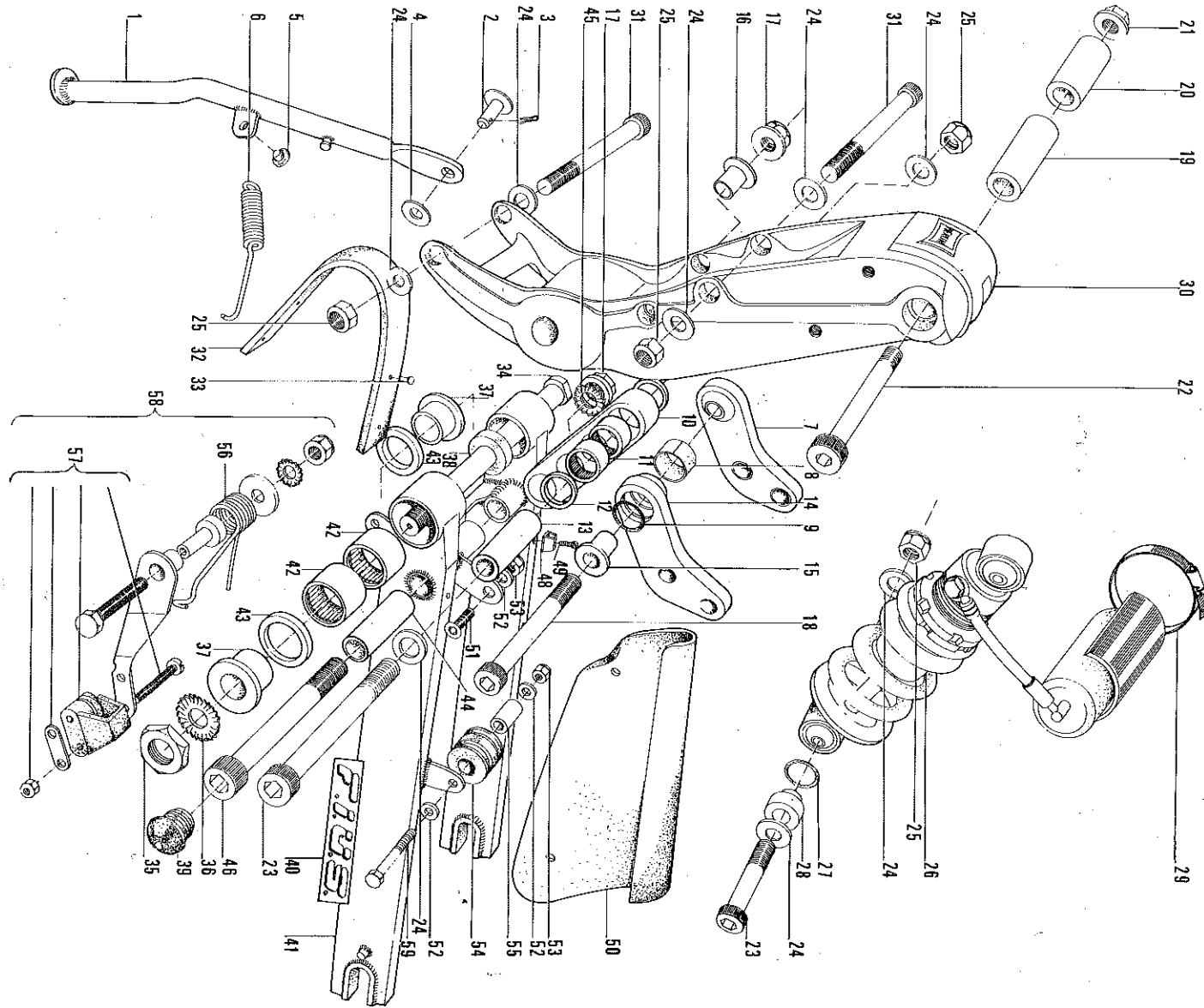

SUSPENSIÓN TRASERA  
SUSPENSION ARRIERE  
REAR SUSPENSION

LAMINA-5

MERLIN

N.º NRO. NBR	REFERENCIA REFERENCE REFERENCE	Denominación	Designation	Description	Cantidad OTE QTY	VALIDEZ VALIDITE VALIDITY
1	013.00.013-0	Caballero	Béquille	Side Stand	1	
2	012.00.048-2	Eje caballero	Axe béquille	Side stand pin	1	
3	072.98.001-0	Pasador abierto		Pin	1	
4	061.98.001-1	Arandela	Rondelle	Washer	1	
5	132.98.001-0	Goma	Caoutchouc	Rubber	1	
6	013.00.015-0	Muelle	Resort	Spring	1	
7	013.03.014-0	Soporte amortiguador dcho.	Support amortisseur droite	Right side Shock support	1	
8	150.98.200-0	Cojinete fricción	Douille	Shock support bearing	2	
9	145.98.001-0	Anillo torico	Joint torrique	"O" Ring	4	
10	017.03.016-0	Biale	Bielle	Push rod	1	
11	160.98.401-9	Cojinete	Roulement	Needle bearing	4	
12	135.98.002-9	Retén	Bourrage	Cil seal	4	
13	017.03.022-0	Casquillo superior	Douille	Top bushing	1	
14	013.03.015-0	Soporte amortiguador izdo.	Support amortisseur gauche	Left side shock support	1	
15	017.03.018-0	Casquillo	Douille	Bushing	2	
16	017.03.020-0	Casquillo	Douille	Bushing	1	
17	054.98.003-1	Tuerca	Douille	Bushing Nut	1	
18	014.98.003-1	Tornillo	Ecrou	Nut Bolt	1	
19	013.03.021-1	Casquillo l.	Vis	Bolt	1	
20	013.03.007-1	Casquillo D.	Douille G.	L. Bushing	1	
21	054.98.002-1	Tuerca	Ecrou	R. Bushing Nut	1	
22	014.98.001-1	Tornillo	Vis	Bolt	1	
23	014.98.011-1	Tornillo	Vis	Bolt	2	
24	061.98.001-1	Arandela	Rondelle	Washer	8	
25	045.98.001-1	Tuerca	Ecrou	Nut	4	
26	017.03.005-0	Amortiguador Jto. torica	Amortisseur Joint	Shock absorber "O" Ring	1	
27	145.98.008-9	Casquillo	douille	sushing	2	
28	017.03.035-1	Abrazadera	Collier	Clamp	2	
29	134.98.002-1	Soporte motor	Support moteur	Engine support	1	
30	017.06.002-0	Tornillo	Vis	Bolt	1	
31	012.98.009-1	Plancha protección	Protection	Chain protector	2	
32	013.03.008-0	Remache	Rivet	Rivets	1	
33	099.98.002-9	Eje basculante	Axe bras oscilante	Suringarm axle	4	
34	013.03.004-1	Tuerca	Ecrou	Nut	1	
35	054.98.201-1	Arandela	Rondelle	Spring Washer	1	
36	064.98.001-0	Casquillo	secrétée	Bushing	1	
37	017.03.006-0	Casquillo	Douille	Bushing	4	
38	013.03.012-0	Tapón goma	Bouchon caont.	Rubber cap	1	
39	132.98.002-9	Adesivos FIUS	Adesif FIUS	FIUS stickers	2	
40	013.03.029-1	Basculante	Bras oscillant	Swing arm	2	
41	017.03.001-0	Cojinete	Roulement	Needle bearings	1	
42	160.98.400-9	Retén	agujas	bearings	4	
43	135.98.001-9	Casquillo inferior	Bourrage	Oil seal	4	
44	017.03.023-0	Arandela	Douille	Bottom bushing	1	
45	067.98.501-0	Tornillo	inferieur	Spring washer	1	
46	014.98.003-1	Tuerca	Rondelle	Bolt	1	
47	054.98.003-1	Grapa	Ecrou	Nut	1	
48	133.98.001-0	Tornillo	Support	Clamp Bolt	2	
49	026.98.004-1	Cubrecadena	Vis	Nut	1	
50	007.19.004-0	Tornillo	Carter de chain	Chain guard Bolt	1	
51	021.98.155-1	Arandela	Vis	Washer	1	
52	061.98.052-1	Tuerca	Rondelle	Nut	3	
53	045.98.004-1	Rodillo	Ecrou	Nut	2	
54	003.19.013-0	Casquillo	Roulette	Roller	1	
55	003.19.012-0	Muelle	Douille	Bushing	1	
56	003.19.007-1	Patín	Resort	Spring	1	
57	003.19.017-1	Cto. tensor	Patín	Slider	1	
58	003.19.013-0	Tornillo	Tendeur Chain	Chain tensioner	1	
59	007.98.010-1	Tornillo	Vis	Bolt	1	

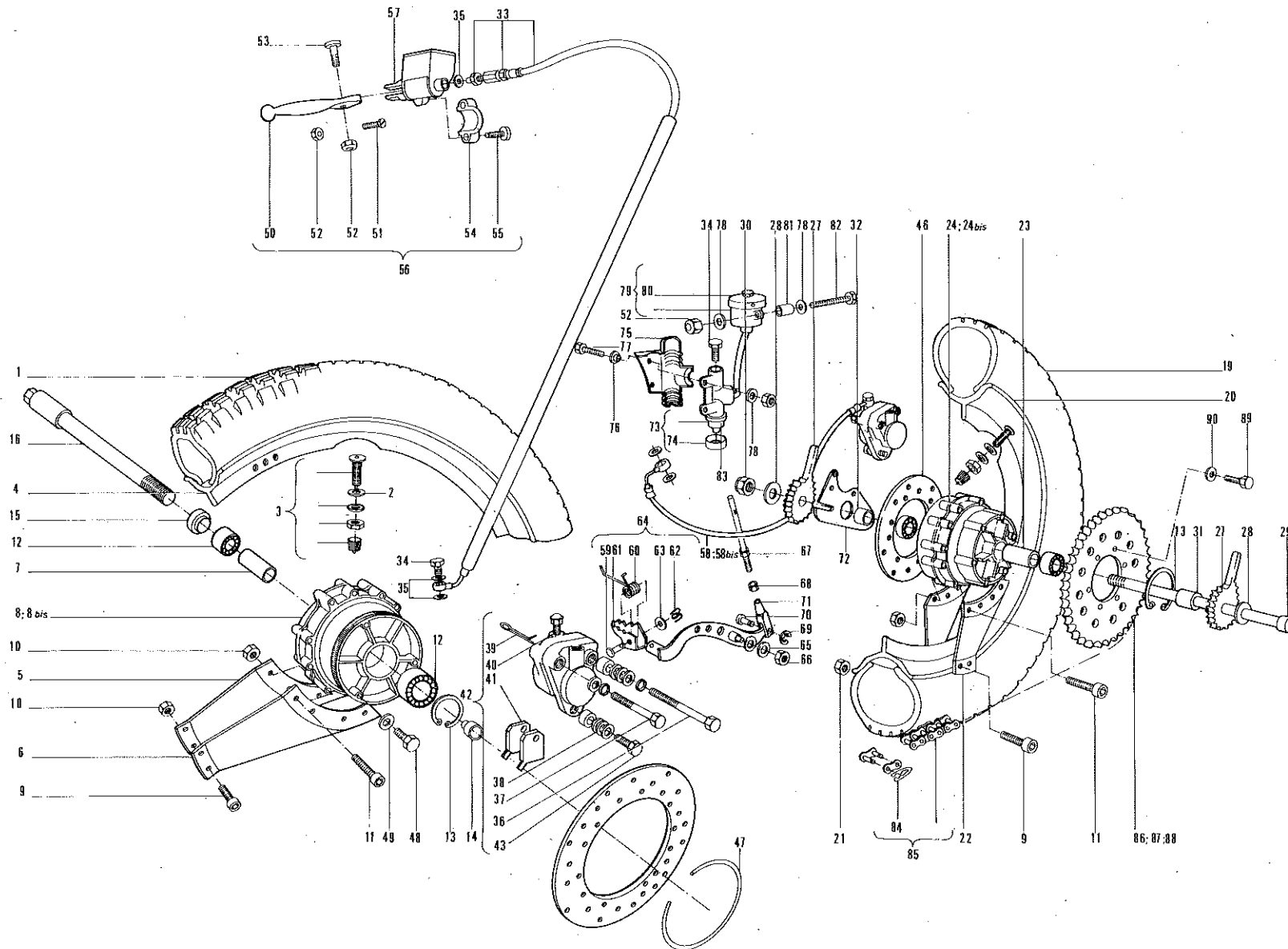

**RUEDAS Y FRENOS  
ROUES ET FREINS  
WHEELS, BRAKES ASSY**

**LAMINA-6**



N.º NRO. NBR.	REFERENCIA REFERENCE REFERENCE	DENOMINACION	DESIGNATION	DESCRIPTION	CANTIDAD QTE. QTY.	VALIDEZ VALIDITE VALIDITY	N.º NRO. NBR.	REFERENCIA REFERENCE REFERENCE	DENOMINACION	DESIGNATION	DESCRIPTION	CANTIDAD QTE. QTY.	VALIDEZ VALIDITE VALIDITY
1	012.04.012-0	Cubierta ant.	Pneu. avant	Front tire	1		48	002.98.005-1	Tornillo	Vis	Bolt	6	
2	067.98.004-9	Junta valvula	Joint	Gasket	2		49	061.98.056-3	Arandela	Rondelle	Washer	6	
3	012.04.020-0	Válvula aire	Soupape a aire	Air valve	2		50	013.09.013-0	Leva freno	Lever frein	Front brake lever	1	
4	013.04.001-1	Llanta ant.	Jante avant	Front rim	1		51	013.09.004-0	Tornillo regulador	Vis réglage	Adjusting bolt	1	
5	013.04.003-0	Brazo L. docho.	Bras droite	Right side spoke	3		52	045.98.004-7	Tuerca	Ecrou	Nut	5	
6	013.04.022-0	Brazo L. izdo.	Bras gauche	Left side spoke	3		53	012.98.012-1	Tornillo	Vis	Bolt	1	
7	013.04.016-1	Cas. entre coji.	Doville	Bushing	1		54	013.09.025-0	Tapeta	Support	Bracket	1	
8	013.04.007-1	Cubo rueda completo, fijación por seeger	Moyeau fixation disque par seeger	Hub disk fixation by seeger	1		55	012.98.002-1	Tornillo	Vis	Bolt	2	
8 bis	013.04.007-2	Cubo rueda completo, fijación disco con tornillo	Moyeau fixation disque par vis	Hub disk fixation by bolts	1		56	017.09.003-0	Cto. mando bomba fr. del.	Pompe frein complete	Front brake máster cylinder assy	1	
9	014.98.006-3	Tornillo	Vis	Bolt	12		57	017.09.027-0	Kit reparación bomba	Kit réparation pompe	Master cylinder repair kit (front)	1	
10	045.98.004-3	Tuerca	Ecrou	Nut	36		58	013.10.002-0	Latiguillo del. goma	Tuyau frein ar. caoutchouc	R. brake hose rubber	1	
11	023.98.001-3	Tornillo	Vis	Bolt	24			017.10.002-0	Latiguillo del. aeroquip	Tuyau frein arr. protection metallique	R. brake hose steel	1	
12	159.98.376-9	Rodamiento	Roulement	Bearing	5		59	013.10.018-0	Puntera	point pedal frein	Brake pedal peg	1	
13	093.98.003-0	Seeger	Bague élastique	Snap ring	4		60	013.10.020-0	Muelle	Resort	Spring	1	
14	013.04.009-1	Casquillo	Doville	Bushing	1		61	013.10.019-0	Eje	Axe	Pin	1	
15	013.04.021-1	Casquillo	Doville	Bushing	1		62	072.98.003-0	Pasador abierto	Goupille	Cotter pin	1	
16	013.04.010-1	Eje r. delan.	Axe roue av.	Front wheel axle	1		63	061.98.002-1	Arandela	Rondelle	Washer	1	
17	013.04.001-1	Cto. rueda del. 4,5,6,8,9,10,11	Roue av. complete	Front wheel assy	1		64	013.10.003-0	Cto. Pedal freno	Pedal frein complete	Rear brake pedal assy	1	
18	013.04.001-2	Cto. rueda del. 4,5,6,8 bis, 9,10,11	Roue av. complete	Front wheel assy	1		65	061.98.053-1	Arandela	Rondelle	Washer	1	
19	012.05.012-0	Cubierta tras.	Pneu arriere	Rear tire	1		66	045.98.003-1	Tuerca	Ecrou	Nut	1	
20	013.05.002-0	Llanta trasera	Jante arriere	Rear rim	1		67	017.10.005-0	Varilla	Tirant	Rod	1	
21	013.05.003-0	Brazo derecho	Bras droite	Right side spoke	3		68	042.98.002-1	Tuerca	Ecrou	Nut	1	
22	013.05.022-0	Brazo izquierdo	Bras gauche	Left side spoke	3		69	092.98.201-0	Seeger	Bague elastique	Snap. ring	1	
23	013.05.016-0	Cas. entre coji.	Doville	Bushing	1		70	013.98.040-0	Eje	Axe	Pin	1	
24	013.05.007-0	Cubo rueda comp. fijación disco con seeger	Moyeau complete fixation disque avec seeger	Front hub assy disk fixation by seeger	1		71	017.10.039-0	Cto. charnela	Fouchette complète	Fork assy	1	
24 bis	013.05.007-1	Cubo rueda comp. fijación discon con tornillo	Moyeau complete. fixation disque avec vis	Front hub assy disk fixation by bolt	1		72	013.10.901-1	Soporte pinza	Support étrier	Caliper support	1	
25	013.05.001-0	Cto. rueda tras. 20,21,22,24,9,10,11	Roue ar. comp.	Rear wheel assy	1		73	013.10.012-0	Cto. bomba trasera	Pompe arriere complete	R. brake master cylinder assy	1	
26	013.05.001-1	Cto. rueda trasera 20,21,22,24 bis,9,10,11	Roue ar. complete	Rear wheel assy	1		74	013.10.014-0	Guardapolvo bomba	Protection pompe	Dust cover	1	
27	017.05.011-0	Excéntrica tensora	Tendeur de chain	Chain tightener	2		75	013.10.041-0	Protección	Protecteur	Cover	1	
28	017.05.021-1	Arandela	Rondelle	Washer	2		76	013.10.042-0	Casquillo	Entretoise	Bushing	2	
29	017.05.010-1	Eje rueda trasera	Axe roue ar.	Rear wheel axle	1		77	007.98.016-1	Tornillo	Vis	Bolt	2	
30	045.98.002-1	Tuerca	Ecrou	Nut	1		78	061.98.004-1	Arandela	Rondelle	Washer	6	
31	013.05.009-0	Casquillo L. izdo.	Entretoise gche.	Left spacer	1		79	013.10.034-0	Cto. depósito	Réservoir	Fluid reservoir	1	
32		Casquillo L. docho.	Entretoise dte.	Right spacer	1		80	013.10.035-0	Tapón depósito	Couvercle réservoir	Reservoir cap	1	
33	013.09.002-0	Latiguillo del. goma	Tuyau frein av. caoutchou	F. Brake hose rubber	1		81	013.10.008-0	Casquillo	Entretoise	Bushing	1	
	017.09.002-0	Latiguillo del. aeroquip	Tuyau frein av. protection metallique	F. brake hose steel braided	1		82	007.98.015-1	Tornillo	Vis	Bolt	1	
34	098.98.001-3	Tornillo especial	Vis especial	Special bolt	3		83	013.10.027-0	Kit reparación bomba trasera	Kit réparation pompe arriere	Master cylinder repair kit (rear)	1	
35	067.98.201-9	Junta	Joint	Gasket	7		84	013.19.002-0	Enganche cadena	Accouplement	Master link	1	
36	007.98.017-1	Tornillo	Vis	Bolt	2		85	017.19.001-0	Cto. cadena	Chaîne complete	Chain assy	1	
37	007.98.002-1	Tornillo	Vis	Bolt	2		86	003.19.005-0	Corona Z:42 serie	Couronne Z: 42 serie	Sprocket Z: 42 std.	1	
38	061.98.003-1	Arandela	Rondelle	Washer	3		87	003.19.015-0	Corona Z: 40	Couronne Z: 40	Sprocket Z: 40	1	
39	072.98.002-0	Pasador abierto	Goupille	Cotter pin	4		88	003.19.016-0	Corona Z: 44	Couronne Z: 44	Sprocket Z: 44	1	
40	013.09.030-1	Sangrador	Soupape	Bleeder	2		89	008.98.001-1	Tornillo	Vis	Bolt	6	
41	013.09.010-0	Pastilla freno	Patin	Brake pads	4		90	067.98.401-3	Arandela muella	Rondelle	Spring washer	6	
42	013.09.018-0	Cto. pinza	Etrier compl.	Caliper assy	2								
43	002.98.001-1	Tornillo	Vis	Bolt	2								
44	013.10.038-0	Casquillo	Entretoise	Spacer	4								
45	067.98.201-1	Arandela grueso 0'5	Rondelle epaisseur 0'5	Washer 0'5 thick									
	067.98.202-1	Arandela grueso 1'0	Rondelle epaisseur 1'0	Washer 1'0 thick									
	067.92.203-1	Arandela grueso 1'5	Rondelle epaisseur 1'5	Washer 1'5 thick									
46	013.09.006-0	Disco freno	Disque frein	Disk	2								
47	095.98.001-0	Seeger	Bague elastique	Snap ring	2								

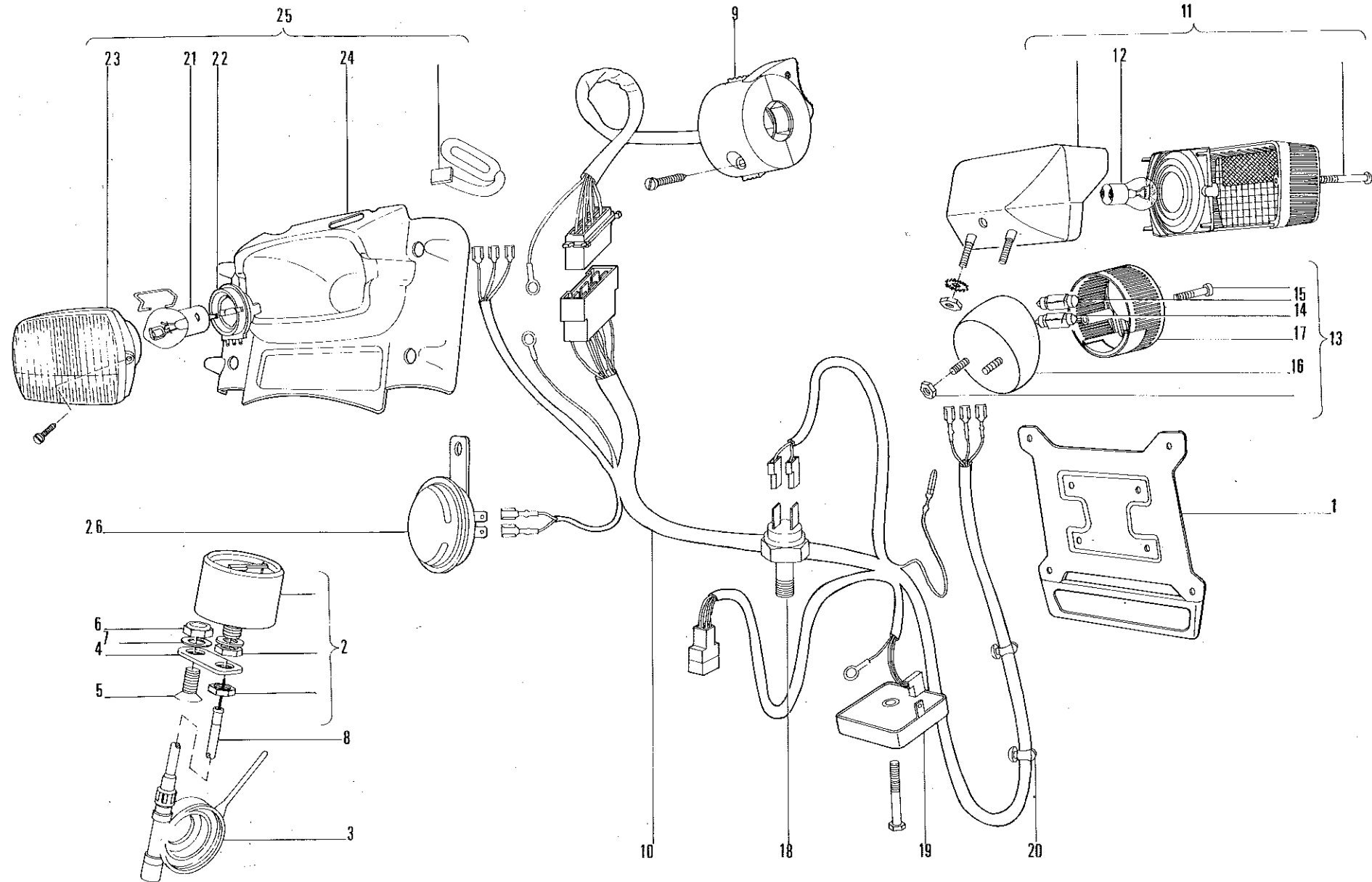

COMPONENTES ELÉCTRICOS  
INSTALLATION ELECTRIQUE  
ELECTRICAL COMPONENTS

LAMINA-7

MERLIN

N.º NRO. NBR.	REFERENCIA REFEENCE REFERENCE	Denominación	Designation	Description	Cantidad QTE QTY	VALIDEZ VALIDITE VALIDITY
1	017.08.012-0	Soporte matrícula	Support plaque	Licence plate	1	
2	017.16.001-0	Cta. Km.	Compteur	Tacometer	1	
3	017.16.002-0	Reenvio	Renvoi	Drive unit	1	
4	017.16.004-0	Soporte	Support	Support	1	
5	023.98.151-1	Tornillo	Vis	Bolt	1	
6	045.98.003-1	Tuerca	Ecrou	Nut	1	
7	061.98.053-1	Arandela	Rondelle	Washer	1	
8	017.16.053-1	Cable	Cable	Cable	1	
9	003.18.001-0	Conmutador	Conmutateur	Switch	1	
10	017.18.002-0	Instalación	Cables	Wiring assy	1	
11	017.18.008-0	Faro Piloto	Feu arriére	Tail light assy	1	
12	1406.38.011-0	Lámpara	Lampe	Bulb	1	
13	003.18.008-0	Faro piloto	Feu arriére	Tail light assy	1	
14	003.18.005-0	Lámpara 12v/ 5w	Lampe 12v/5w	Bulb 12v/5w	1	
15	003.18.006-0	Lámpara 12v/ 21w	Lampe 12v/21w	Bulb 12v/21w	1	
16	003.18.015-0	Portalámpara	Porte lampe	Bulb support	1	
17	003.18.016-0	Cristal	Loupe	Lens	1	
18	017.18.009-0	Interruptor stop	Interrupteur stop	Stop light switch	1	
19	003.18.010-0	Regulador tensión	Regulateur tension	Tension regulator	1	
20	017.18.020-0	Sujeción Instalación	Collier pour	Wiring clamp	1	
21	003.18.004-0	Lámpara	Lamp	Bulb	1	
22	003.18.014-0	Portalámpara	Porte lampe	Bulb holder	1	
23	012.18.017-0	Grupo óptico	Groupe optique	Lens assy	1	
24	012.18.018-0	Soporte grupo óptico	Support groupe optique	Lens support	1	
25	012.18.003-0	Cto. faro del.	Fare ant. complete	Front light assy	1	
26	003.18.007-0	Claxon	Claxon	Horn	1	

CULATA, CILINDRO, PISTON, CIGÜEÑAL  
CULASSE, CYLYNDRE, PISTON ET MANIVELLE  
CYLINDER HEAD, CYLINDER, PISTON, GRANKSHAFT

LAMINA-8

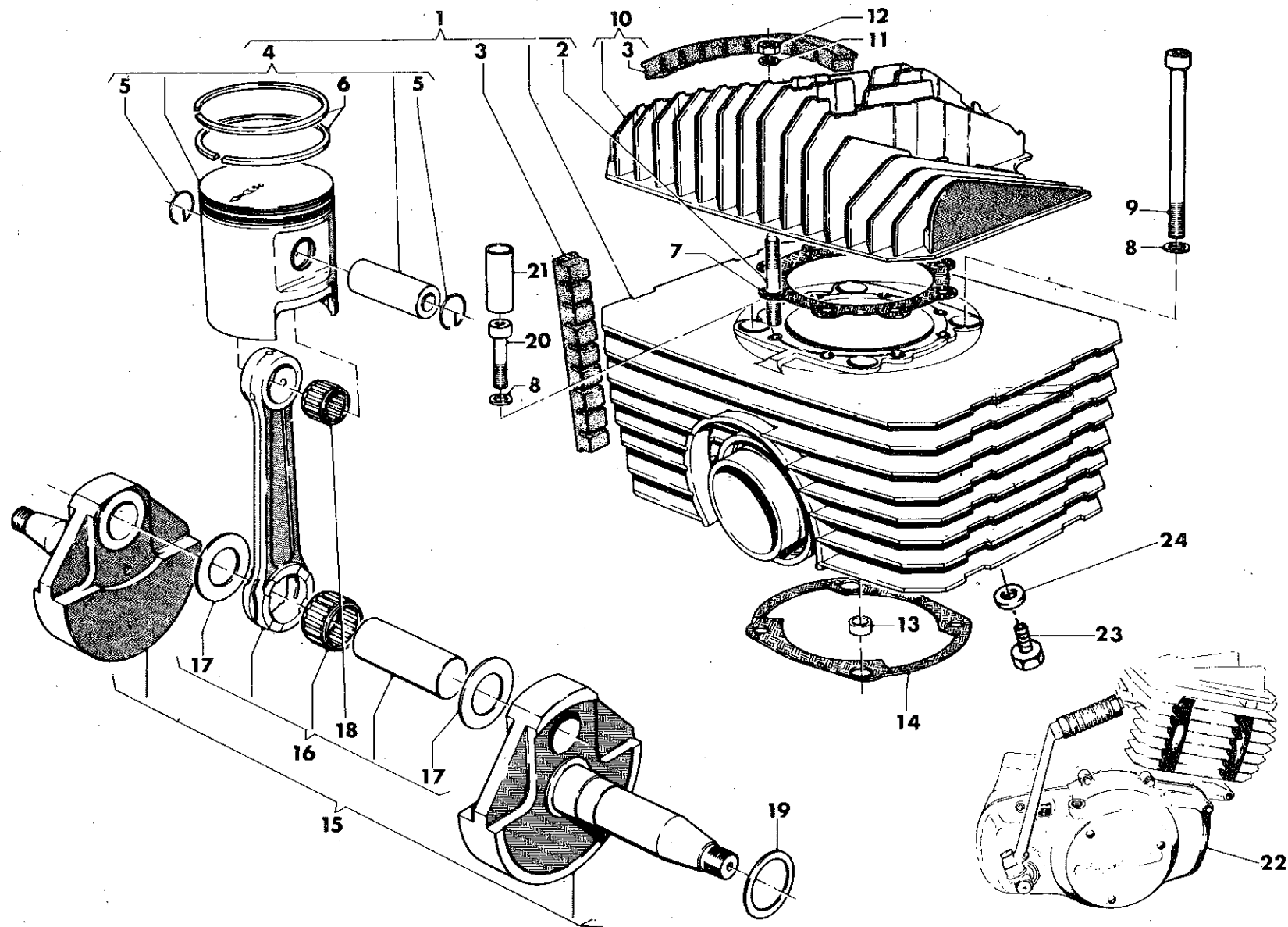

CULATA, CILINDRO, PISTON, CIGUEÑAL  
 CULASSE, CYLYNDRE, PISTON ET MAUIVELLE  
 CYLINDER HEAD, CYLINDER, PISTON, CRANKSHAFT

LAMINA-8

MERLIN

N.º NRO. NBR.	REFERENCIA REFERENCE REFERENCE	Denominación	Designation	Description	Cantidad QTE. QTY	VALIDEZ VALIDITE VALIDITY
1	CA 051208-0	Cjto. cilindro-pistón	Cylindre et piston compl.	Cylinder piston assy	1	
2	CA 029236-0	Espárrago	Goujon	Stud	8	
3	CA 024903-0	Antivibrante	Peigne pour ailette	Rubber plug. cyl. fins	3	
4		Cto. pistón	Piston compl. couleur:	Piston assy coulor:	1	
	CA 051212-1	Azul Ø 79,96 - 79,96	Bleu Ø 79,96 + 79,96	Blue Ø 79,96 + 79,96	1	
	CA 051212-2	Rosa Ø 79,97	Rose Ø 79,96 + 79,97	Pink Ø 79,96 + 79,97		
	CA 051212-3	Verde Ø 79,97 - 79,98	Verte Ø 79,97 + 79,98	Green Ø 79,97 + 79,98		
	CA 051212-4	Amarillo Ø 79,98 - 79,99	Jaune Ø 79,98 + 79,99	Yellow Ø 79,98 + 79,99		
5	CA 024793-0	Seeger bulón	Bague d'arrêt	Lock ring	2	
6	CA 031152-0	Juego aros	Couple de segments	Set of piston ring	1	
7	CA 024797-7	Junta 0,7 mm	Joint épais. 0,7 mm	Gasket, thick 0.7 mm	1	
8	CA 023374-0	Arandela	Rondelle	Washer	4	
9	CA 002599-0	Tornillo	Vis	Screw	2	
10	CA 043759-0	Culata	Culasse compl.	Head assy	1	
11	CA 017811-0	Arandela	Rondelle	Washer	8	
12	CA 015008-0	Tuerca	Ecrou	Nut	8	
13	CA 027583-0	Centraje	Douille	Bush	2	
14	CA 024796-0	Jta. cilindro 0,5 mm	Joint ép. 0,5 mm	Gasket th. 0,5 mm	1	
15	CA 026919-0	Gigüeñal	Vilebrequin compl.	Crankshaft assy	1	
16	CA 029689-0	Bieta	Bielle moteur compl.	Connecting rod assy	1	
17	CA 024782-0	Arandela bieta	Rondelle	Washer	2	
18	CA 028851-0	Jaula pie biela	Cage à aiguilles	Needle bearing	1	
19		Arandela grueso	Rondelle épaisseur:	Washer thick:		
	CA 010350/20	0,2 mm	0,2 mm	0,2 mm	1	
	CA 010350/30	0,3 mm	0,3 mm	0,3 mm	1	
	CA 010350/40	0,4 mm	0,4 mm	0,4 mm	1	
	CA 010350/50	0,5 mm	0,5 mm	0,5 mm	1	
	CA 010350/60	0,6 mm	0,6 mm	0,6 mm	1	
	CA 01035/70	0,7 mm	0,7 mm	0,7 mm	1	
	CA 010350/80	0,8 mm	0,8 mm	0,8 mm	1	
	CA 010350/90	0,9 mm	0,9 mm	0,9 mm	1	
	CA 010350/100	1,0 mm	1,0 mm	1,0 mm	1	
	CA 010350/110	1,1 mm	1,1 mm	1,1 mm	1	
20	CA 002591-0	Tornillo	Vis	Screw	2	
21	CA 029716	protector tornillo	Tuyau de protection	Guard pipe	2	
22	013.06.001-0	Cto. Motor	Engine assy	Motcur compl.	1	
23	CA 001076-0	Tornillo	Vis	Screw	1	
24	CA 015673-0	Arandela	Rondelle	Washer	1	
	CA 36665-0	Kit juntas y retenes	Serie de joint et segments	E Engine rings and seal set	1	

CARTERS CENTRALES  
CARTER CENTRAL  
CENTER GRANKCASE

LAMINA-9

MERLIN

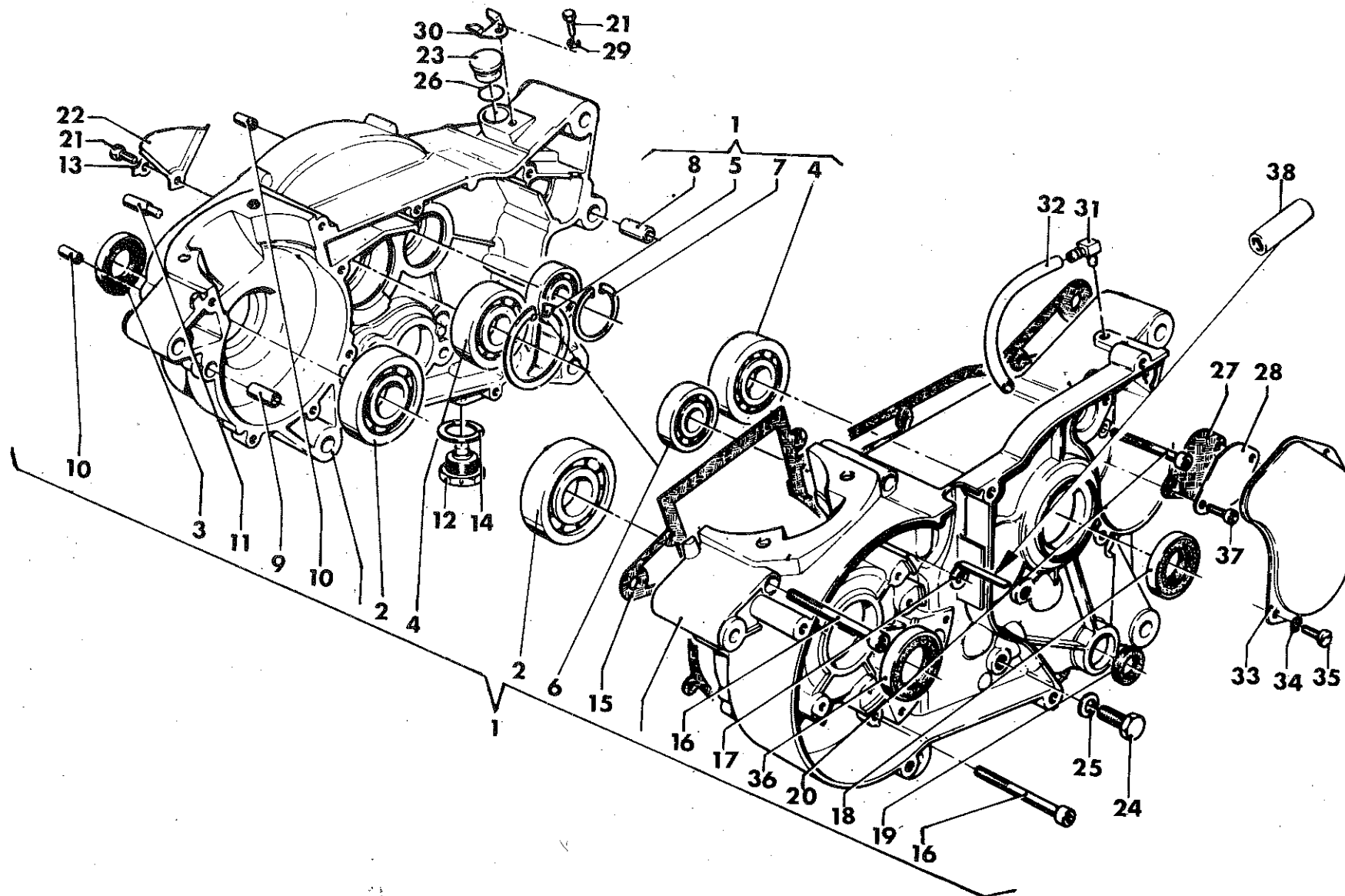

GG3 FIUS.



CARTERS CENTRALES  
CARTER CENTRAL  
CENTER CRANKCASE

LAMINA-9

MERLIN

N.º NRO. NBR.	REFERENCIA REFERENCE REFERENCE	Denominación	Designation	Description	Cantidad QTE QTY	VALIDEZ VALIDITE VALIDITY
1	CA 043751-0	Cto. cárter con rodam.	Carters assemblés, com.	Crankcase assy. cplt. With bearings	1	
2	CA 016794-0	Rodamiento	Roulement.	Bearing crankshaft	2	
3	CA 026210-0	Retén	Bague d'étanchéite	Seal. crankshaft	1	
4	CA 017853-0	Rodamiento	Roulement	Bearing trasmission	2	
5	CA 021295-0	Seeger	Bague d'arrel	Lock ring	1	
6	CA 019768-0	Rodamiento	Rouiemnt	Bearing trasmission	2	
7	CA 021270-0	Seeger	Bague d'arrêt	Lock ring	1	
8	CA 010419-0	Centraje	Douille	Dowel bushing rear	1	
9	CA 033687-0	Centraje	Douille	Dowel bushing right	1	
10	CA 007719-0	Centraje	Douille	Dowel bushing right	2	
11	CA 019574-0	Pitón muelle	Cliquet	Pin, pawl carrier return spring	1	
12	CA 011524-0	Tapón vaciado	Bouchon	Drain plug, trasmission	1	
13	CA 008146-0	Arandela seguridad	Rondelle d'arrêt	Lock wascher	1	
14	CA 006725/3	Junta tapón	Rondelle d'étanchéité	Washer	1	
15	CA 043754-0	Junta cárter central	Joint	Gasket, cranc. center	1	
16	CA 002948-0	Tornillo	Vis	Screw	11	
17	CA 024319-0	Planchita	Plaquette	Guide, altern. cables output		
18	CA 022959-0	Retén	Bague d'étanchéite	Oil seal, trasmission	1	
19	CA 022946-0	Retén	Bague d'étanchéité	Oil seal, shifter shaft	1	
20	CA 002944-0	Tornillo	Vis	Screw	2	
21	CA 001077-0	Tornillo	Vis	Screw	2	
22	CA 019622-0	Plancha	Plaquette	Plate, oiler	1	
23	CA 023580-0	Tapón	Bouchon	Plug	1	
24	CA 001537-0	Tornillo	Vis	Screw	1	
25	CA 015587-0	Arandela	Rondelle	Washer	1	
26	CA 021917-0	Junta tórica	Bague d'étanchéité	"O" ring	1	
27	CA 027327-0	Junta	Joint	Gasket	1	
28	CA 027326-0	Tapa	Flasque	Cover	1	
29	CA 015536-0	Arandela seguridad	Rondelle élastique	Lock washer	1	
30	CA 019487-0	Planchita	Plaquette	Plate	1	
31	CA 019620-0	Respiradero	Raccord d'évent	Breather union	1	
32	CA 019621-0	Tubo	Tuyau d'évent	Breather tube	1	
33	CA 022903-0	Tapa	Couvercle	Cover	1	
34	CA 015535-0	Arandela	Rondelle élastique	Spring washer	2	
35	CA 002898-0	Tornillo	Vis	Screw	2	
36	CA 030728-0	Retén	Bague d'étanchéite	Seal, crankshaft	1	
37	CA 002483-0	Tornillo	Vis	Screw	2	
38	CA 035476-0	Funda prot. cables	Tuyau	Tube	1	

CARTERS LATERALES  
COUVERCLES CARTER  
SIDE CASES

LAMINA-10

MERLIN

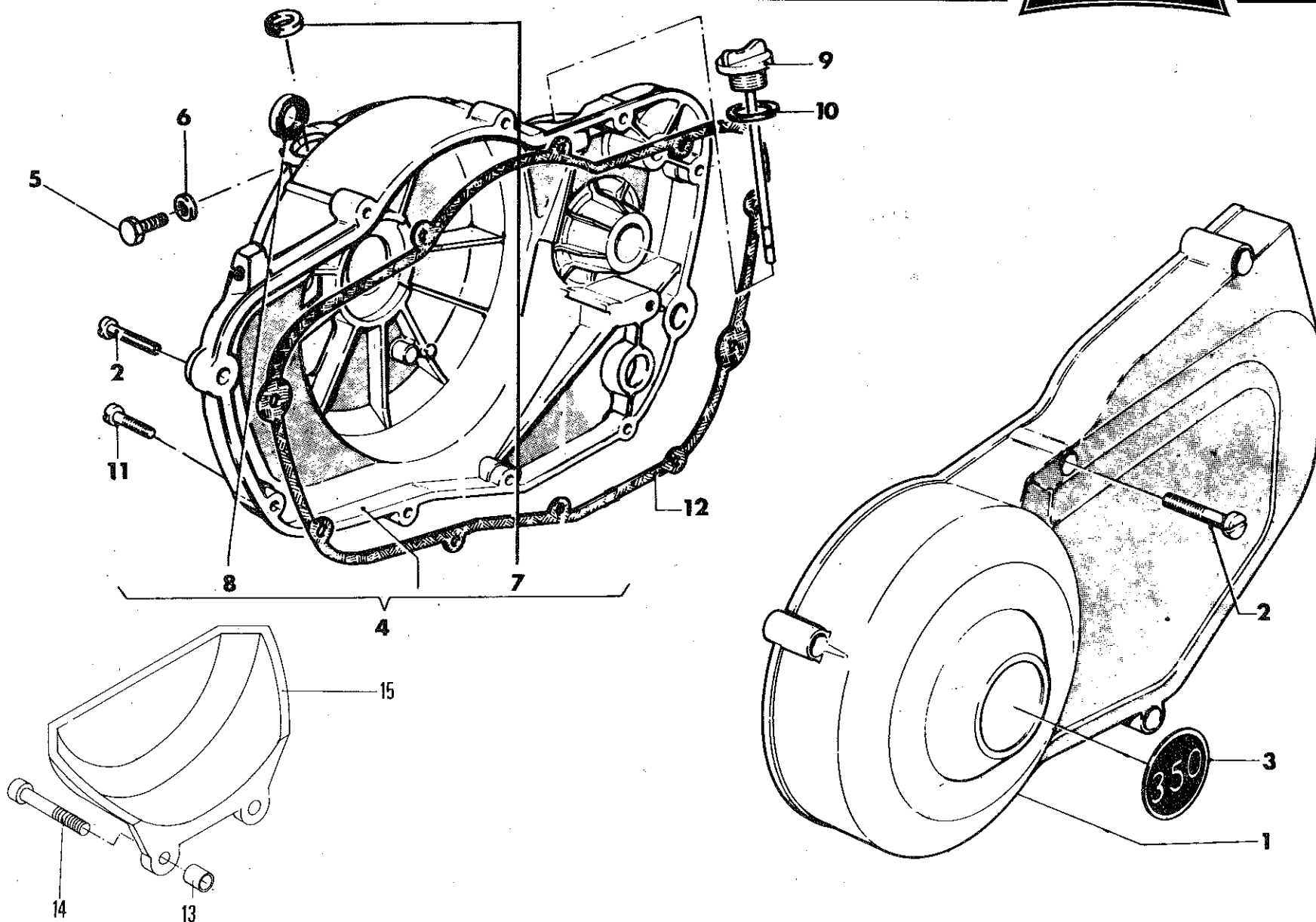

CARTERS LATERALES  
COUVERCLES CARTER  
SIDE CASES

LAMINA-10



N.º NRO. NBR.	REFERENCIA REFERENCE REFERENCE	Denominación	Designation	Description	Cantidad QTE QTY	VALIDEZ VALIDITE VALIDITY
1	CA 026507-0	Tapa volante	Couvercle G.	Crankcase cover, left	1	
2	CA 002512-0	Tornillo	Vis	Screw	6	
3	CA 028300-0	Calcomania	Décalcomanie	Transfer	1	
4	CA 034972-0	Tapa embrague	Ansemble couvercle D.	Crankcase cover, right	1	
5	CA 031388-0	Tornillo	Vis	Screw	1	
6	CA 015580-0	Arandela	Rondelle	Washer	1	
7	CA 022946-0	Retén	Bague d'étanchéité	Seal ring	1	
8	CA 027022-0	Retén	Bague d'étanchéité	Oil seal-starter shaft	1	
9	CA 019623-0	Tapón llenado	Bouchoun d'huile	Filter plug	1	
10	CA 027960-0	Junta tapón llenado	Rondelle d'étanchéité	Sealing washer	1	
11	CA 002510-0	Tornillo	Vis	Screw	6	
12	CA 019583-0	Junta tapa	Joint	Gasket	1	
13	003.06.004-0	Casquillo	Entretoise	Bushing	2	
14	012.98.007-1	Tornillo	Bolt	Vis	2	
15	003.06.003-0	Protección	Case protector	Protection carter	1	

PUESTA EN MARCHA  
MISE EN MARCHE  
KICK STARTER

LAMINA-11

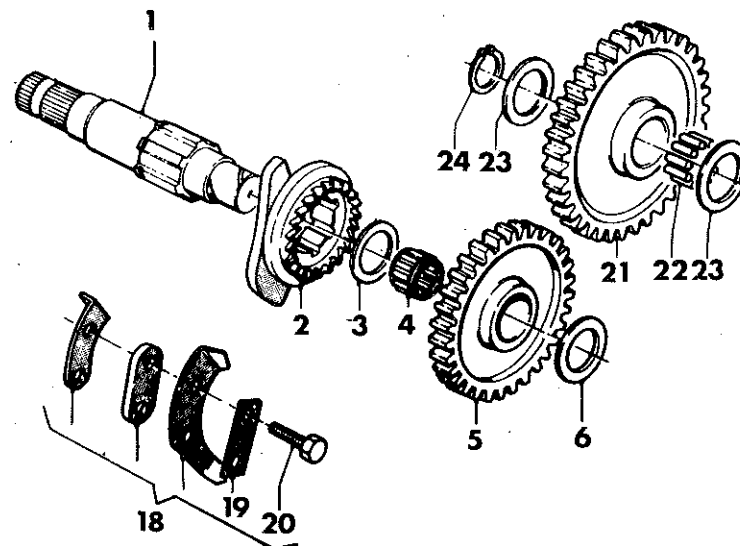
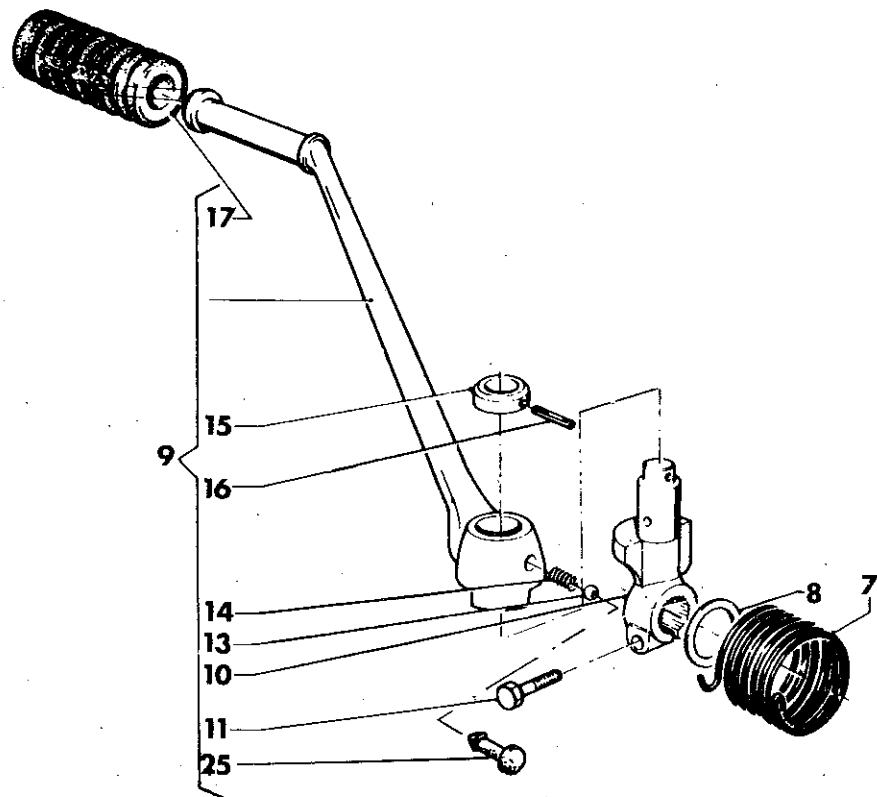

PUESTA EN MARCHA  
MISE EN MARCHE  
RICK STARTER

LAMINA-11

MERLIN

N.º NRO. NBR.	REFERENCIA REFERENCE REFERENCE	Denominación	Designation	Description	Cantidad QTE QTY	VALIDEZ VALIDITE VALIDITY
1	CA 028362-0	Eje P.E.M.	Arbre de démarrage	Starter crankshaft	1	
2	CA 019646-0	Trinquete P.E.M.	Manchon	Ratcher starter	1	
3	CA 010904/10	Arandela	Rondelle d'épaulement	Washer, thrust	1	
4	CA 022372-0	Jaula agujas	Cage à aiguille	Needle roller bearing	1	
5	CA 034305-0	Engranaje Z:29	Engrenage Z:29	Ratcher gear Z:29	1	
6	CA 010485/8	Arandela	Rondelle d'épaulement	Washer thrust	1	
7	CA 019647-0	Muelle retorno	Ressort	Spring	1	
8	CA 07989/10	Arandela	Rondelle d'épaulement	Washer thrust	1	
9	CA 030406-0	Cto. Leva P.E.M.	Levier complet	Starter crank assy	1	
10	CA 030405-0	Eje Leva P.E.M.	Eton	Clamp starter crank	1	
11	CA 001143-0	Tornillo	Vis	Screw	1	
13	CA 0021507-0	Esfera 1/4"	Bille 1/4"	Ball starter crank 1/4"	1	
14	CA 023073-0	Muelle situador leva P.M.	Ressort	Spring	1	
15	CA 026337-0	Arandela	Rondelle	Washer	1	
16	CA 055035-0	Pasador elástico	Goupille élastique	Spring pin	1	
17	CA 026338-0	Protección goma	Manchon	Rubber, starter pedal	1	
18	CA 026196-0	Tope trinquete	Kit de plaquettes	Plate realese	1	
19	CA 020474-0	Plancha de seguridad	Plaquette d'arrêt	Plate	1	
20	CA 001083-0	Tornillo	Vis	Screw	2	
21	CA 034303-0	Piñon libre Z:28	Engrenage de renv. Z:28	Idle Wheel Z:28	1	
22	CA 022375-0	Agujas jaula	Cage à aiguilles	Needle roller bearing	1	
23	CA 04553/100	Arandela	Rondelle d'épaulement	Washer, thrust	2	
24	CA 021204-0	Seeger	Bague élastique	Snap ring	1	
25	CA 033777-0	Tapón	Bouchon	Plug	1	



TRANSMISIÓN PRIMARIA, EMBRAGUE  
TRANSMISSION PRIMAIRE, EMBRAYAGE  
PRIMARY TRANSMISSION, CLUTCH

LAMINA-12

MERLIN

N.º NRO. NBR.	REFERENCIA REFERENCE REFERENCE	Denominación	Designation	Description	Cantidad QTE QTY	VALIDEZ VALIDITE VALIDITY
1	CA 036264	Cto. primaria	Engrenages pour transmission primaire	Set of matched primary drive gears	1	
2	CA 034966-0	Cojinete axial	Roulement	Bearing	1	
3	CA 024423-0	Casquillo	Entretoise	Spacer	1	
4	CA 001081-0	Tornillo	Vis	Screw	1	
5	CA 027733-0	Arandela	Rondelle	Washer clutch gear	1	
6	CA 028461-0	Arandela	Rondelle d'épaulement	Washer thrust	1	
8	CA 034967-0	Arandela	Rondelle	Washer	1	
11	CA 032000-0	Plato de empuje	Plaque de pression compl.	Clutch releasing disc assy	1	
12	CA 039823-0	Cubo embrague	Moyeu porte-disques	Clutch hub assy	1	
13	1406.16.670-0	Discos forrados	Disque conducteur	Drive plate	5	
14	CA 020779-0	Discos metálicos	Disque intérieur	Driven plate	5	
15	CA 022979-0	Disco exterior	Disque conducteur fr.	Outer plate	1	
16	CA 022348-0	Seeger	Bague élastique	Snap ring	1	
17	CA 029089-0	Arandela de seguridad	Rondelle d'arrêt	Washer lock-tab	1	
18	CA 03170-0	Tuerca	Ecrou	Nut	1	
19	CA 0		Paque débrayage	Clutch release plate	2	
20	CA 019640-0	Arandela seguridad	Rondelle d'arrêt	Washer lock-tab	6	
21	CA 001053-0	Tornillo	Vis	Screw	6	
22	CA 040343-0	Palanca	Levier	Lever	1	
23	CA 031485-0	Cremallera	Cremalleire	Rack	1	
24	CA 032720-0	Eje	Arbre	Shaft	1	
25	CA 035015-0	Cto. cojinete axial	Ensemble débrayage	Clutch release assy	1	
26	CA 003171-0	Arandela de seguridad	Rondelle d'arrêt	Washer lock-tab	1	
27	CA 031455-0	Tuerca	Ecrou	Nut	1	
28	CA 036997-0	Muelle	Ressort	Spring	1	
29	CA 036346-0	Seeger	Bague élastique	Snap ring	1	
30	CA 051159-0	Muelle	Resort	Spring	6	

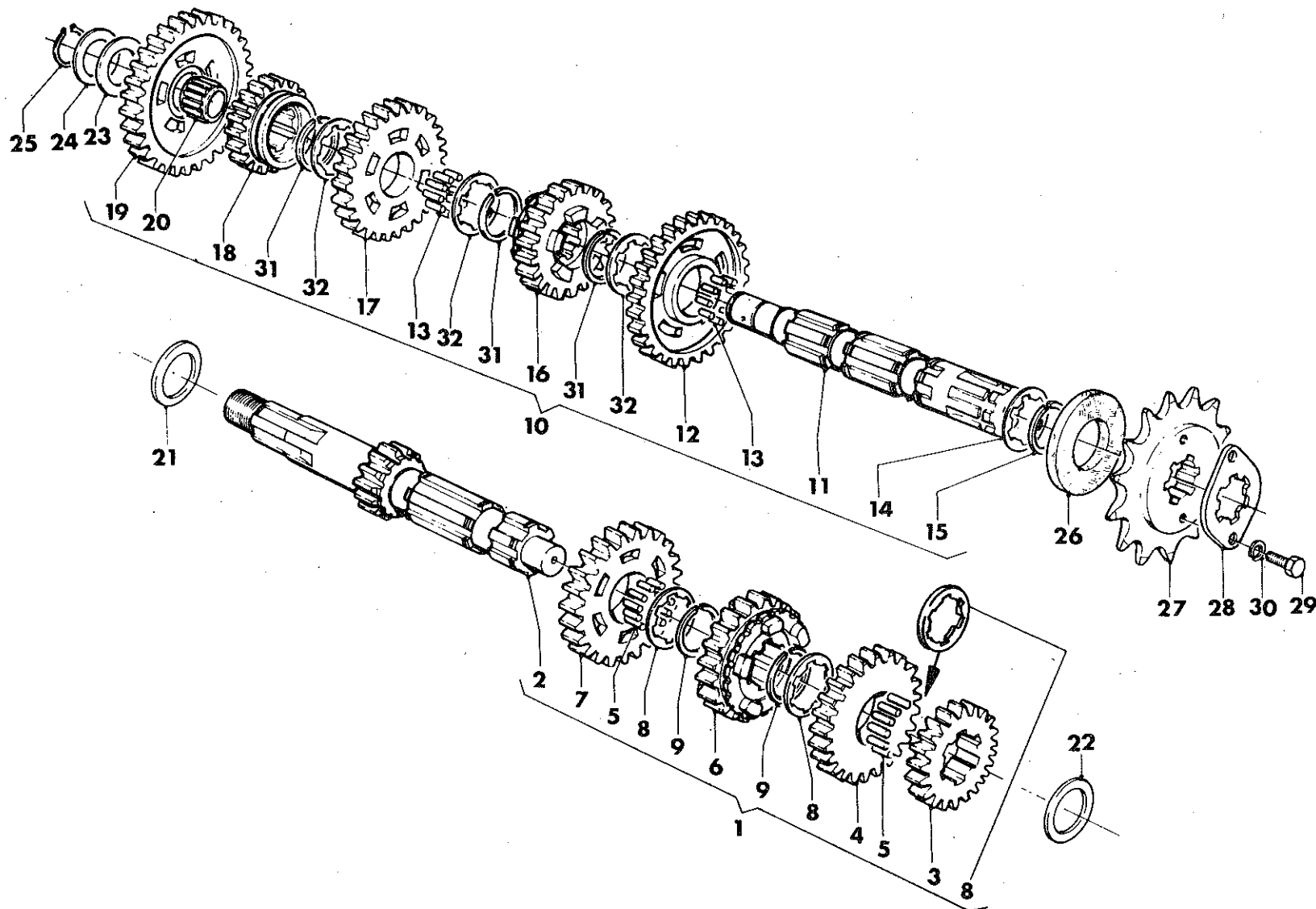

CAMBIO DE MARCHAS  
BOITE DE VITESSE  
GEAR BOX

LAMINA-13

MERLIN

N.º NRO. NBR.	REFERENCIA REFERENCE REFERENCE	Denominación	Designation	Description	Cantidad QTE. QTY	VALIDEZ VALIDITE VALIDITY
1	CA 051152-0	Cto. eje primario	Arbre primaire compl.	Main shaft assy	1	
2	CA 051153-0	Eje primario Z:11	Arbre primaire Z:11	Main shaft Z:11	1	
3	CA 05154-0	Piñón 2.º fijo Z:13	Pignon 2ème AS Z:13	Gear main shaft 2nd. Z:13	1	
4	CA 038989-0	Piñón 4.º libre Z:21	Pignon 4ème AS. Z:21	Gear main shaft 4th Z:21	1	
5	CA 030793-0	Rodillos	Rouleau	Needle	50	
6	CA 038990-0	Piñón 3.º Libre Z:16	Pignon 3ème AP. Z:16	Gear main shaft 3rd. Z:16	1	
7	CA 038991-0	Piñón 5.º libre Z: 26	Pignon 5ème AP Z:26	Gear main shaft 5th. Z:26	1	
8	CA 023736-0	Arandela	Rondelle d'épaulement	Thrust washer	3	
9	CA 023529-0	Seeger	Bague elastique	Spring ring	3	
10	CA 051156-0	Cto. eje secundario	Arbre secondaire compl.	Countershaft assembly	1	
11	CA 036254-0	Eje secundario	Arbre secondaire	Countershaft	1	
12	CA 051157-0	Piñón 2.º libre Z:35	Pignon 2ème AS. Z:35	Gear main shaft 2nd. Z:35	1	
13	CA 021545-0	Rodillos	Rouleau	Needle	56	
14	CA 025145-0	Arandela	Rondelle d'épaulement	Thrust washer	1	
15	CA 023529-0	Seeger	Bague elastique	Spring ring	1	
16	CA 038994-0	Piñón 4.º despl. Z:26	Pignon 4ème AS Z:26	Gear main shaft 4th. Z:26	1	
17	CA 051158-0	Piñón 3.º libre Z:31	Pignon 3ème AS. Z:31	Gear main shaft 3th. Z:31	1	
18	CA 038996-0	Piñón 5.º despl. Z:20	Pignon 5ème AS. Z:20	Gear main shaft 5th Z:20	1	
19	CA 036281-0	Piñón 1.º libre Z:36	Pignon 1ère AS. Z:36	Gear main shaft 1th. Z:36	1	
20	CA 022121-0	Rodamiento	Cage à aiguille	Bearing	1	
21	CA 016930/20	Arandelas	Rondelle d'épaisseur	Thrust washer	1	
	CA 016930/40		0,2 mm	0,2 mm	1	
	CA 016930/60		0,4 mm	0,4 mm	1	
			0,6 mm	0,6 mm	1	
22	CA 013332/30	Arandela	Rondelle d'épaisseur	Thrust washer	1	
	CA 013332/50		0,3 mm	0,3 mm	1	
	CA 013332/80		0,5 mm	0,5 mm	1	
			0,8 mm	0,8 mm	1	
23	CA 04553/20	Arandela	Rondelle d'épaisseur	Thrust washer		
	CA 04553/30		0,2 mm	0,2 mm		
	CA 04553/40		0,3 mm	0,3 mm		
	CA 04553/50		0,4 mm	0,4 mm		
	CA 04553/60		0,5 mm	0,5 mm		
	CA 04553/70		0,6 mm	0,6 mm		
	CA 04553/80		0,7 mm	0,7 mm		
	CA 04553/90		0,8 mm	0,8 mm		
	CA 04552/100		0,9 mm	0,9 mm		
			1,0 mm	1,0 mm		
24	CA 04881/80	Arandela	Rondelle d'épaisseur	Thrust washer	1	
	CA 04881/90		0,8 mm	0,8 mm	1	
	CA 04881/100		0,9 mm	0,9 mm	1	
	CA 04881/110		1,0 mm	1,0 mm	1	
	CA 04881/120		1,1 mm	1,1 mm	1	
	CA 04881/130		1,2 mm	1,2 mm	1	
	CA 04881/150		1,3 mm	1,3 mm	1	
	CA 04881/160		1,5 mm	1,5 mm	1	
	CA 021204-0	Seeger	Bague elastique	Spring ring	1	
25	CA 031036-0	Piñón cadena Z:11	Pignon Z:11	Drive sprocket Z:11	1	
27	CA 031035-0	Piñón cadena Z:10 (standard)	Pignon Z:10 (standard)	Drive sprocket Z:10 (standard)	1	
	CA 019532-0	Piñón cadena Z:15	Pignon Z:15	Drive sprocket Z:15	1	
28	CA 031037-0	Placa para Z:11	Plaque pour Z:11	Plate for Z:11	1	
	CA 031038-0	Placa para Z:10	Plaque pour Z:10	Plate for Z:10	1	
29	CA 002462-0	Tornillo	Vis	Screw	2	
30	CA 015534-0	Arandela	Rondelle d'épaulement	Spring washer	2	
31	CA 026177-0	Seeger	Bague elastique	Spring ring	3	
32	CA 026176-0	Arandela	Rondelle d'épaisseur	Thrust washer	3	

SELECTOR  
SELECTEUR  
SELECTOR

LAMINA-14

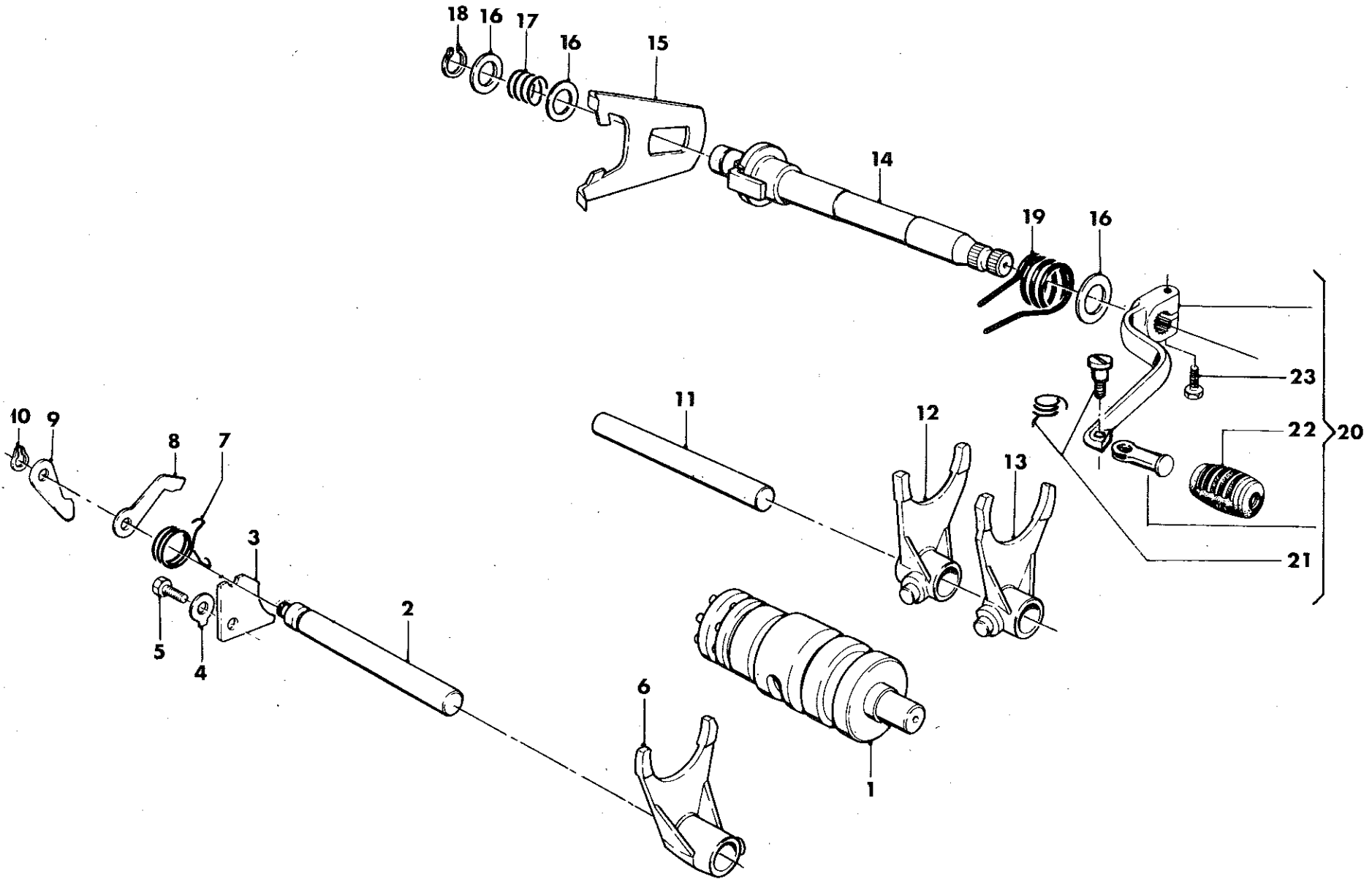



N.º NRO. NBR.	REFERENCIA REFERENCE REFERENCE	Denominación	Designation	Description	Cantidad QTE QTY	VALIDEZ VALIDETE VALIDITY
1	CA 027005-0	Tambor de selector	Tambour selecteur	Selector drum	1	
2	CA 024054-0	Eje horquilla 4.ª 5.ª	Axe de fourche 4ème- 5ème-5ème vit.	Pin 4 th. 5th. gear shifter fork	1	
3	CA 019594-0	Plancha retención	Plaquette	Retaining plate	1	
4	CA 008146-0	Arandela seguridad	Rondelle d'arrêt	Lock washer	1	
5	CA 001078-0	Tornillo	Vis	Screw	1	
6	CA 036280-0	Horquilla 4.ª 5.ª	Fourche 4ème-5ème V.	Fork. gear shifter. 4th.5th	1	
7	CA 019600-0	Muelle	Ressort	Ratchel spring	1	
8	CA 019599-0	Situador (pto. muerto)	Cliquet (point mort)	Pawl. inner (neutral)	1	
9	CA 019598-0	Situador de marchas	Cliquet d'arrêt	Positioning pin	1	
10	CA 021375-0	Seeger	Jonc d'arrêt	Snap ring	1	
11	CA 019593-0	Eje horquilla 1.ª, 1.ª, 3.ª	Axe de fourche 1ère- 2ème - 3ème vit.	Pin 1st-2st-3rd gear shifter fork	1	
12	CA 031053-0	Horquilla 1.ª	Fourche 1ère vit.	Fork-gear shifter 1st	1	
13	CA 020962-0	Horquilla 2.ª 3.ª	Fourche 2ème-3ème	Fork-gear shifter 2st-3st	1	
14	CA 027010-0	Eje selector	Arbre du sélecteur	Shifter shaft	1	
15	CA 019602-0	Selecteur	Plaque du sélecteur	Selector plate	1	
16	CA 004553-10	Arandela	Rondelle	Washer	3	
17	CA 019603-0	Muelle	Ressort	Spring	1	
18	CA 021203-0	Seeger	Bague d'arrêt	Snap ring shaft	1	
19	CA 019605-0	Muelle retorno	Ressort	Return spring	1	
20	CA 028285-0	CTO. Pedal selector	Pedale complete	Shift lever assy	1	
21	CA 029862-0	Muelle y eje puntera	Axe et ressort	Pivot and spring	1	
22	CA 029861-0	Protección goma	Manchon	Rubber pedal	1	
23	CA 001081-0	Tornillo	Vis	Screw	1	

ENCENDIDO  
ALUMAGE  
IGNITION

LAMINA-15

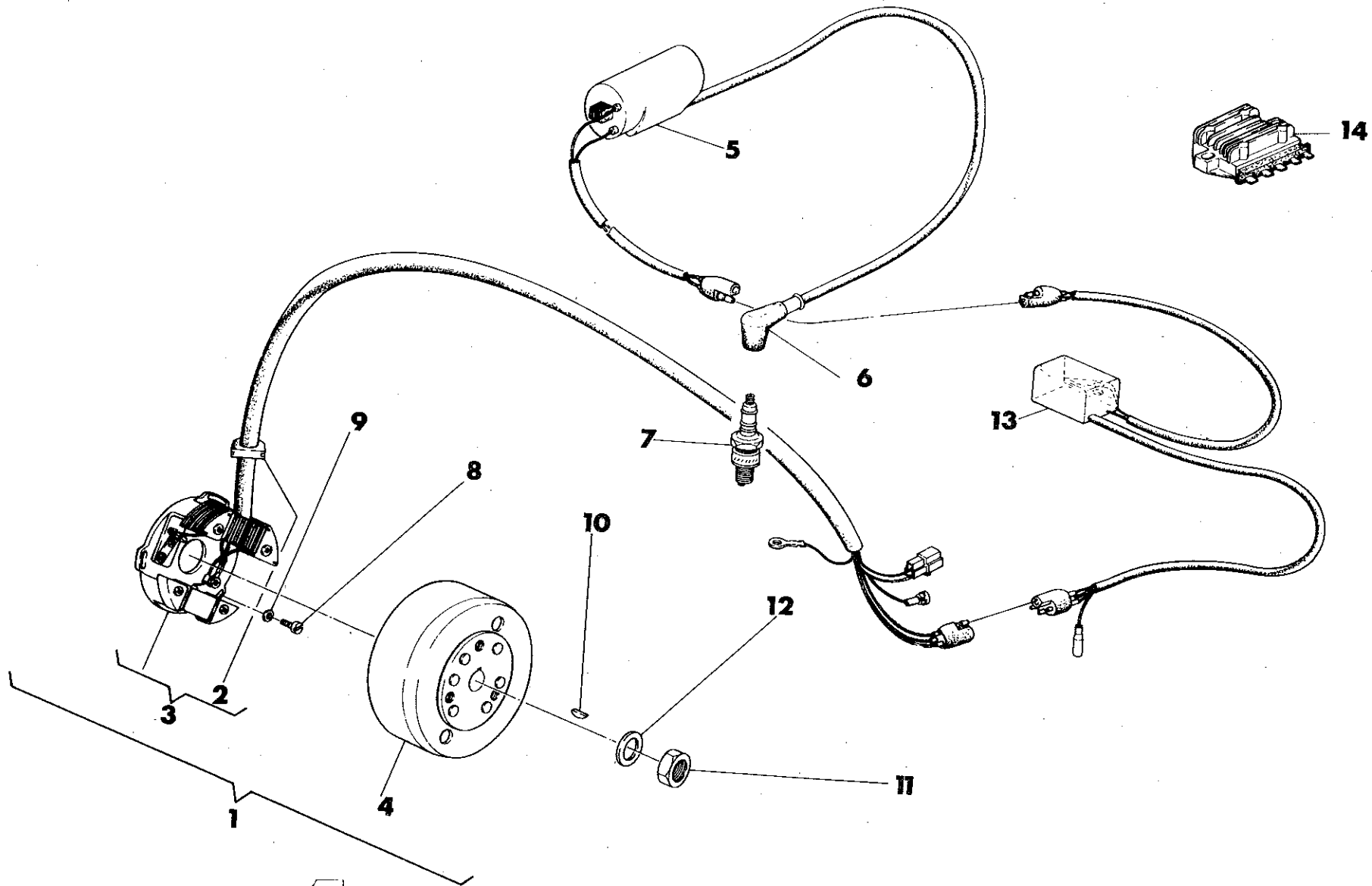

ENCENDIDO  
ALUMAGE  
IGNITION

LAMINA-15

MERLIN

N.º NRO. NBR.	REFERENCIA REFERENCE REFERENCE	Denominación	Designation	Description	Cantidad QTE QTY	VALIDEZ VALIDITE VALIDITY
1	CA 037548-0	Cto. volante kokusan	Alternator electronique compl.	Electronic alternator assy	1	
2	CA 020311-0	Goma pasacables	Guide cable	Cable guide	1	
3	CA 037549-0	Cto. Estator	Base volant compl.	Alternator base assy	1	
4	CA 037008-0	Rotor	Rotor volant	Alternator rotor	1	
5	CA 035570-0	Bobina A.T	Bobine H.T.	H.T. coil	1	
6	CA 039657-0	Pipa bujía	Pipette bougie	Spark plug boot	1	
7	CA 036485-0	Bujía champion N 124	Bougie "champion" N12Y	Spark plug "champion" N12Y	1	
8	CA 002901-0	Tornillo	Vis	Screw	3	
9	CA 015766-0	Arandela	Rondelle	Washer	3	
10	CA 021002-0	Chaveta	Clavette	Key	1	
11	CA 015085-0	Tuerca	Écrou	Nut	1	
12	CA 015544-0	Arandela	Rondelle	Washer	1	
13	CA 035571-0	Centralita electrónica	Central electronique	Ignition module	1	

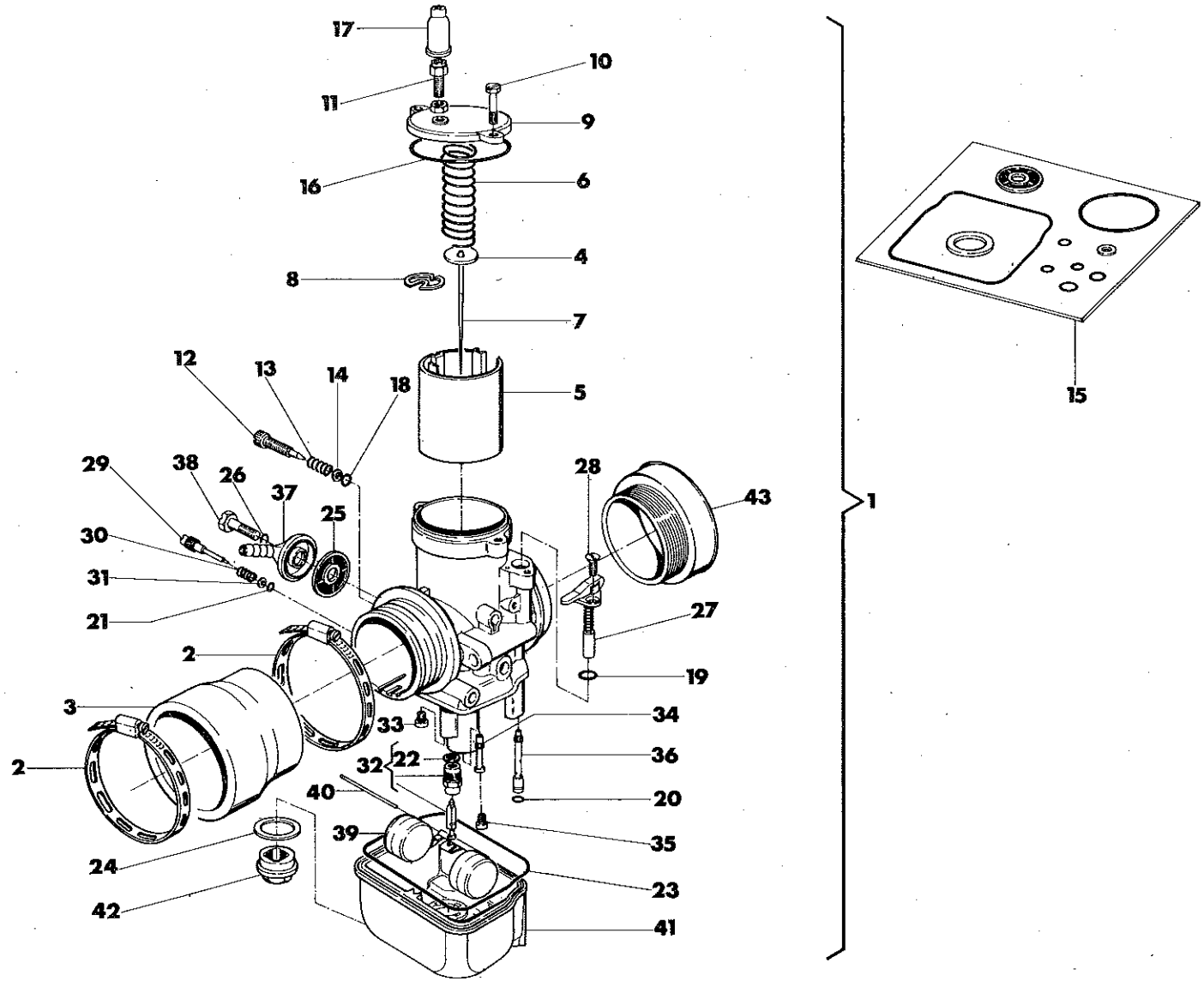

CARBURADOR  
CARBURATEUR  
CARBURETOR

LAMINA-16

MERLIN

N.º NRO. NBR.	REFERENCIA REFERENCE REFERENCE	Denominación	Designation	Description	Cantidad QTE QTY	VALIDEZ VALIDITE VALIDITY
1	CA 043886-0	Cto. carburador	Carburateur complet	Carburetor assy	1	
2	134.98.002-1	Dell'Orto PHBH 28 BD	Dell'Orto PHBH 28 BD	Dell'Orto PHBH 28 BD	2	
3		Brida	Collier	Clamp	1	
4	CA 036682-0	Manguito goma	Manchon	Rubber coupling	1	
5	CA 036681/60	Clip aguja	Plaqueette	Plate	1	
6	CA 035086-0	Compuerta 60	Soupape gaz 60	Slide 60	1	
7	CA 036683/2	Muelle	Ressost	Spring	1	
8	CA 035353-0	Aguja X-2	Pivot X-2	Needle X-2	1	
9	CA 036685-0	Clip	Goujon	Clamp	1	
10	CA 036685-0	Tapa	Couvercle	Cover	2	
11	CA 023981-0	Tornillo	Vis	Srew	1	
12	CA 004103-0	Tensor cable	Vis de réglage	Tensioner	1	
13	CA 012029-0	T. reg. compuerta	Vis de réglage	Slide bolt	1	
14	CA 012030-0	Muelle	Ressort	Spring	1	
15	CA 023983-0	Arandela	Rondelle	Washer	1	
15	CA 035364-0	Kit junta	Kit de joints (comprenant: 16,17,18, 19,20,21,22, 23,24,25,26)	Gasket set (included: 16,17,18, 19,20,21,22, 23,24,25,26)	1	
16	CA 036686-0	Junta	Joint	Gasket	1	
17	CA 012451-0	Protector goma	Capouchon	Cap	1	
18	CA 023982-0	Junta	Joint	Gasket	1	
19	CA 019426-0	Junta	Joint	Gasket	1	
20	CA 012453-0	Junta	Joint	Gasket	1	
21	CA 023984-0	Junta	Joint	Gasket	1	
22	CA 023987-0	Junta	Joint	Gasket	1	
23	CA 035361-0	Junta	Joint	Gasket	1	
24	CA 012042-0	Junta	Joint	Gasket	1	
25	CA 012045-0	Junta	Joint	Gasket	1	
26	CA 003990-0	Junta	Joint	Filter	1	
27	CA 032854-0	Starder	Dispositit de démarrage	Gasket	1	
28	CA 032855-0	Tornillo	Vis	Choke	1	
29	CA 012033-0	Tornillo aire	Vis d'aire	Screw	1	
30	CA 012034-0	Muelle	Ressort	Air screw	1	
31	CA 023985-0	Arandela	Rondelle	Spring	1	
32	CA 035356-0	Flotador	Pointeau du flotteur	Washer	1	
33	CA 005761/45	Chidé ralenti 45	Gicleur ralenti 45	Float valve assy	1	
34	CA 033745/266	Chimenea AV 266	Pulvérisateur AV 266	Pilot jet 45	1	
35	CA 012041/98	Chidé principal 98	Gicleur principal 98	Needle jet AV 266	1	
36	CA 012032/70	Chidé starter	Gicleu démarr 70	Main jet 98	1	
37	CA 012046-0	Entrada gasolina	Tuvau de racord	Choke jet 70	1	
38	CA 012048-0	Tornillo	Vis	Intel elbow	1	
39	CA 035357-0	Flotador 8 gr.	Flotteur 8 gr.	Screw	1	
40	CA 012037-0	Eje flotador	Pivot flotteur	Float 8 gr.	1	
41	CA 035358-0	Cuba	Corps de cuvette	Float pin	1	
42	CA 012040-0	Tapón	Bouchon de cuvette	Float chamber housing	1	
43	CA 036687-0	Acoplamiento	Cornet	Float chamber plug	1	
44	134.98.001-1	Brida	Collier	Coupling	1	
				Clamp	1	

MERLIN

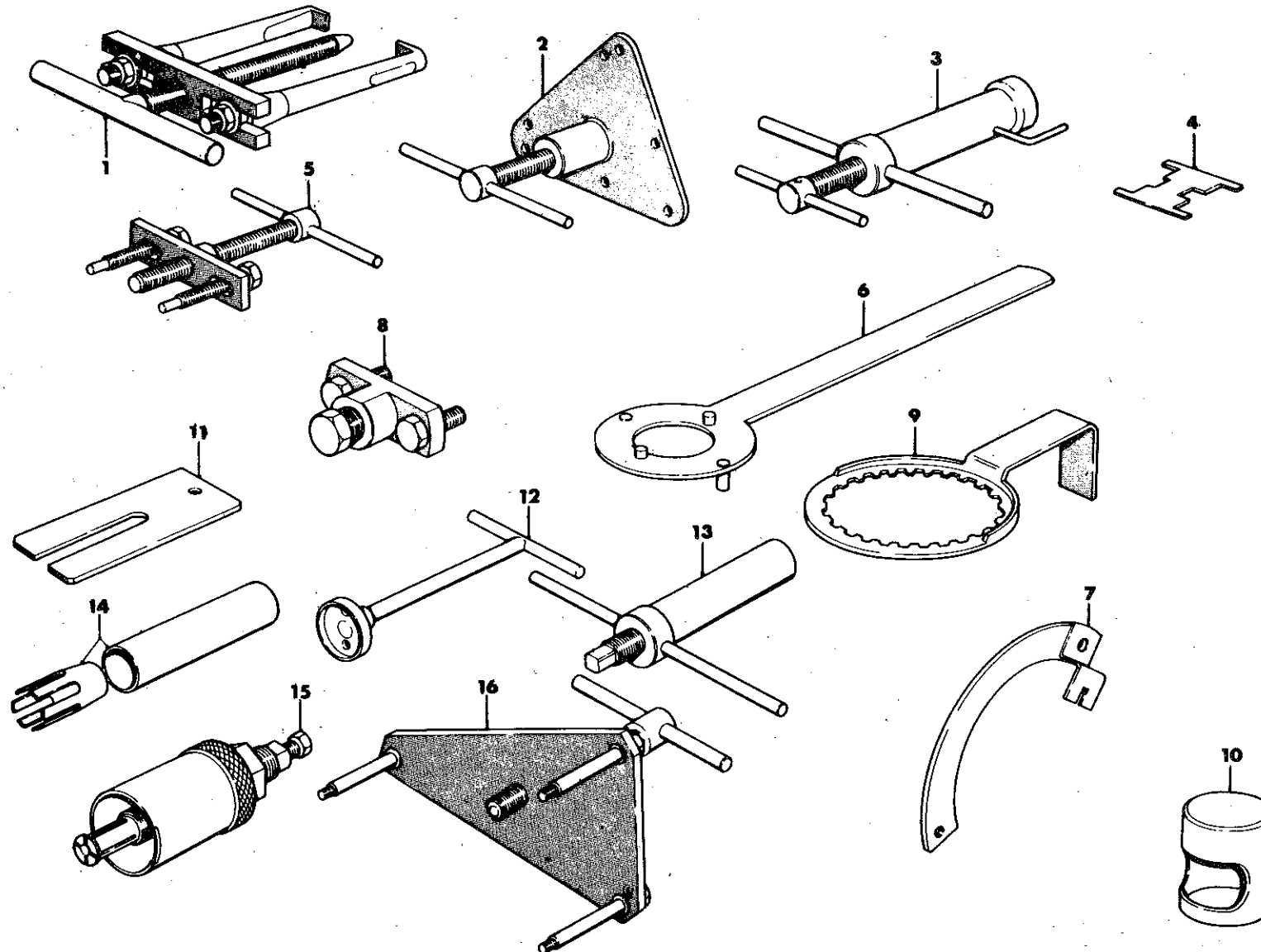

MERLIN

N.º NRO. NRB.	REFERENCIA REFERENCE REFERENCE	Denominación	Designation	Description	Cantidad QTE QTY	VALIDEZ VALIDITE VALIDITY
1	CA YA 1005-0	Extrator universal	Extracteur universel	Two jaw puller	1	
2	CA YA 2268-0	Desmontaje carter C.	Outil démontage dem Carter/vilebrequin	Crankcase splitting tool	1	
3	CA YA 2294-0	Montaje cigüeñal	Outil pour montage vilebrequin dans le demi- carter D.	Installing tool crankshaft shaft right	1	
4	CA YA 2269-0	Control nivel	Gabarit contrôle floft	Carburetor float gage	1	
5	CA YA 2073-0	Extractor cubo embrague	Extracteur moyeu embr.	Clutch hub puller	1	
6	CA 035593-0	Bloqueador rotor	Cle de blocage volant KOKUSAN	Rotor holding tool KOKUSAN	1	
7	CA YA2290-0	Control avance	Plaque réglage avance	Ignition timing setting tool	1	
8	CA 036139-0	Extractor rotor	Extracteur pour volant KOKUSAN	Rotor puller KOKUSAN	1	
9	CA YA2276-0	Bloqueador cubo embr.	Clé de blocage moyeu porte-disques embr.	Clutch hub holding tool	1	
10	CA YA2261-0	Extractor embrague	Douille pour démont. montage disques embr.	Clutch disassembly tool	1	
11	CA YA2263-0	Bloqueador biela	Fourche pour bielle	Connect. rod hold tool	1	
12	CA YA2188-0	Mando tambor selector	Outil pour essai arbre comm. fourche B.V.	Shilfer cam. operator	1	
13	CA YA2267-0	Montaje cigüeñal	Outil pour montage arbre primaire sur le carter D.	Installing tool. crankshaft right	1	
14	CA YA2264-0	Montaje arand. cambio primario	Douilles pour montage rondelles d'épaulement sur arbres I	Trasmission assy tool	1	
	CA YA2292-0	Montaje arandela cambio secundario	Douilles pour montage rondelles d'épaulement sur arbres II	Trasmission assy tool	1	
15	CA YA2293-0	Extractor cojinetes	Extracteur roulement 15X42X13 du carter G	Bearing puller mainshaft 15X42X13 left	1	
16	CA YA2275-0	Extractor seeger embrague	Outil pour extraction jonc d'arrêt du carter d'embrayage	Clutch disassembly tool	1	